

Flexible connectors · Solderless terminals · Contact-systems

druseidt

Elektrotechnik



Product-Information

Highly flexible silicone insulated cold- and heat resistant cables, ready assembled connectors and accessories





Edition: 11/2023 (Info 03/2018)

Paul Druseidt
Elektrotechnische Spezialfabrik GmbH & Co. KG
Neuenkamper Str. 105
42855 Remscheid, Germany

Phone: +49 (21 91) 93 52-0
Telefax: +49 (21 91) 93 52-150
http: www.druseidt.de
E-Mail: info@druseidt.de

The measurements and technical information written in this catalogue have been determined with greatest care and are updated continuously in our documentation. The illustrations correspond to the status at the time of printing. We reserve us the right to make technical as well as changes of measurements, colours or formats after printing.

Our information, especially the values of possible current-loads are not binding, they are only approximate values under optimized conditions. The relation between conductor cross-section and current load fixed in national or international regulations are not cancelled through our information.
Only the values in our written confirmations are binding for us.

The use of photos, drawings or other parts of this catalogue for own advertisement or other usage is subject to our formerly written acceptance.

The druseidt silicone program

With our silicone program we offer the user a large selection of silicone molded round- and flat braids, suitable for continuous operating temperatures - 50 °C up to + 180 °C and operating voltages 1 kV up to 3,6/6 kV. All designs are deliverable as yard goods on rolls or spools as well as ready assembled connectors. Different crimp- and connection technologies enable the production of flexible current transmission elements, which are adapted exactly to customers application.

We supply all components as accessories for the in-house production of cable sets, e. g. an approved UL-listed crimp-technology (cable connectors and tools) as well as suitable cable glands in standard- and high temperature design. With these tested and proven components, the user can produce even highly flexible standard-compliant cable sets and power connections in-house and also document the required quality of the components.



ESSENTIAL ADVANTAGES:

High Quality

- Both cold- and heat resistant
- Highest flexibility
- Free of halogen
- Excellent fire performance

Variety of designs

- Deliverable as round- and flat braid
- Available in designs according to customers requirements
- Available as finished part in solderless pressed or welded design
- Also available with coloured insulation according to customer requirements

Wide range of accessories

- Cable lugs exactly matched to the dimensions of the cables
- UL-listed crimp-technology and cable lugs
- Cable glands exactly matched to the dimensions of the cables
- UL-listed cable glands, so that a complete system consisting out of cables, cable lugs, crimp-technology and cable glands is available

Extremely flexible silicone extruded cables 2,5-300 mm²

Our highly flexible silicone extruded cables are excellently suitable for high current connections inside of switchboards, switch gears and other high current applications. Since more and more systems and devices with high performance but even smaller dimensions are being launched on the market, our cables offer an optimal solution for power connections in tight spaces. A wide temperature range from - 50 °C up to + 180 °C expands the application possibilities.

Both single insulated cables in the voltage range 1,8/3 kV and double insulated designs 1,8/3 kV and 3,6/6 kV are available. All 1,8/3 kV designs are tested and meet the fire protection requirements required for use in the railway industry and similar application. Both variants also have a UL style, which also applies to most of the articles we produce from it.

Extremely flexible

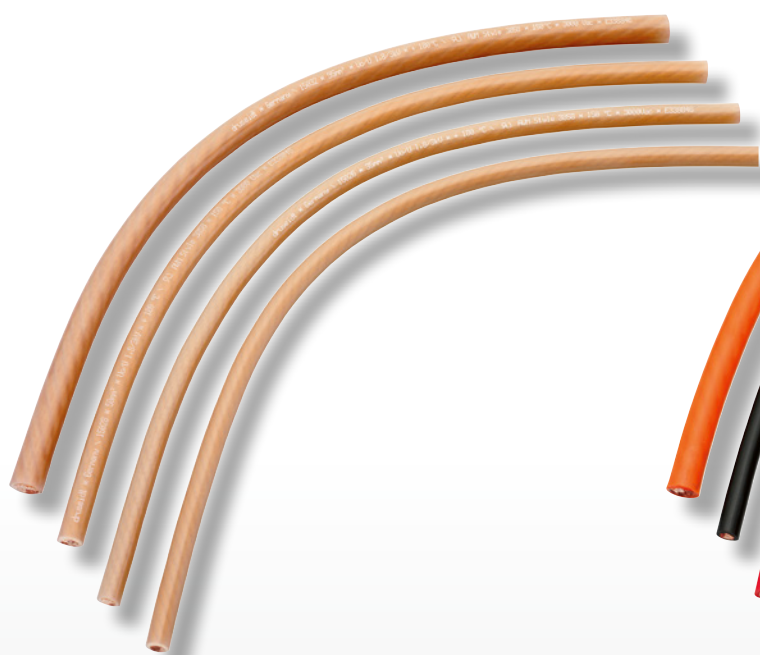

Standard nature coloured



Coloured designs e. g. black, red, orange, blue or yellow/green on request

Silicone insulated copper cables 4-300 mm²

1,8/3 kV, single insulated

Highly flexible, free of halogen, self-extinguishing, with UL-style

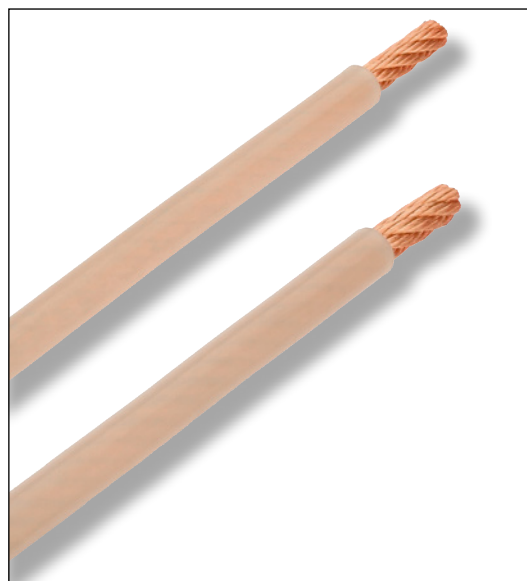

Technical data

Electrical conductor

- Round stranded copper cable out of Cu-ETP 1 wires acc. to DIN EN 13602
- Soft annealed, uncoated
- Single wire-Ø 0,07 mm (4-16 mm²)
Single wire-Ø 0,10 mm (25-300 mm²)

Insulation

- Silicone rubber ca. 60 Shore A
- Natural-coloured
- Free of halogen, Chlorine content < 4 ppm
- Hardly inflammable, self-extinguishing
- Operating voltage 1,8/3 kV
- Testing voltage 10 kV AC (Sparktest)
- Dielectric strength 20 kV/mm
- Operating temperature - 50 °C up to + 180 °C
shortly + 250 °C up to + 300 °C (soldering iron contact)
- Short circuit resistance SiR + 350 °C

Approvals and fire tests

- UL-Style 3858
- DIN EN 60332-1-2/VDE 0482-332-1-2
- DIN EN 60332-3-24/VDE 0482-332-3-24
- DIN EN 61034-2/VDE 0482-1034-2
- DIN EN 50305/VDE 0260-305 Section 9.2

Delivery

- Optionally in rings, on spools or wooden drums

	Part-No.	Technical data								
		Cross-section mm ²	Dimensions mm			Current load in dependence of the conductor heat in °C				
			Diameter and No. of wires	Outer-Ø ca.	Insulation thickness ca.	45 °C	80 °C	90 °C	100 °C	130 °C
1,8/3 kV, single insulated	15014	4,0	1036 x 0,07	4,8	1,1	30 A	50 A	55 A	60 A	70 A
	15016	6,0	1568 x 0,07	5,6	1,1	40 A	65 A	70 A	78 A	90 A
	15020	10,0	2562 x 0,07	8,5	2,0	50 A	90 A	98 A	107 A	120 A
	15022	16,0	4116 x 0,07	10,0	2,0	70 A	125 A	132 A	143 A	160 A
	15024	25,0	3234 x 0,10	12,0	2,3	95 A	160 A	176 A	187 A	215 A
	15026	35,0	4508 x 0,10	13,8	2,5	115 A	200 A	218 A	230 A	260 A
	15028	50,0	6468 x 0,10	15,5	2,5	145 A	245 A	276 A	287 A	325 A
	15030	70,0	8967 x 0,10	18,0	2,5	175 A	305 A	347 A	352 A	400 A
	15032	95,0	12201 x 0,10	20,0	2,5	215 A	370 A	416 A	425 A	485 A
	15034	120,0	15435 x 0,10	21,5	2,5	245 A	425 A	488 A	495 A	560 A
	15036	150,0	19404 x 0,10	23,5	2,5	285 A	490 A	566 A	575 A	640 A
	15038	185,0	23580 x 0,10	26,0	2,5	320 A	555 A	644 A	655 A	730 A
	15040	240,0	30600 x 0,10	28,5	2,5	380 A	650 A	775 A	790 A	855 A
	15042	300,0	38200 x 0,10	32,5	2,5	435 A	750 A	898 A	915 A	985 A

Remark: All information about current load are approximate values in consideration of the cables heat for single laying of air cooled cables and ambient temperature + 30 °C. The values of a conductor heat of + 90 °C are in accordance with VDE 0298 part 4 table 15. By changing the ambient temperature or the kind of laying reducing factors are to be considered. Nature colour is standard but on request it is also possible to manufacture cables with colours like black, red, blue, yellow/green etc. or with reduced insulation thickness and other operating voltages. Minimum quantity on request. The outside diameter of our highly flexible copper conductors are manufactured in consideration with cable lugs acc. to DIN 46234/DIN 46341 and druseidt tubular cable lugs for fine stranded cables.

Silicone insulated copper cables 2,5-300 mm²

1,8/3 kV resp. 3,6/6 kV, double insulated

Highly flexible, free of halogen and self-extinguishing

(New: Now also with UL-file)

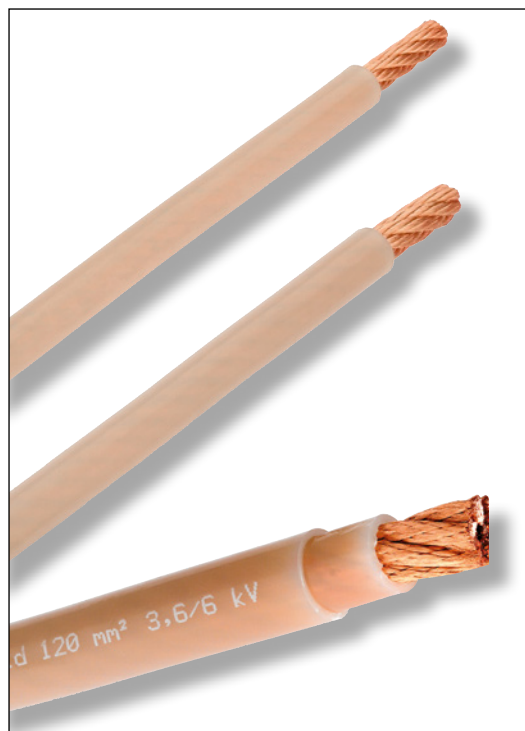

Technical data

Electrical conductor

- Round stranded copper cable out of Cu-ETP 1 wires acc. to DIN EN 13602
- Soft annealed, uncoated
- Single wire-Ø 0,07 mm (2,5-16 mm²)
Single wire-Ø 0,10 mm (25-300 mm²)

Insulation

- Silicone rubber ca. 60 Shore A
- Natural-coloured
- Free of halogen, Chlorine content < 4 ppm
- Hardly inflammable, self-extinguishing
- Operating voltage 1,8/3 kV
- Testing voltage 10 kV AC (Sparktest)
- Dielectric strength 20 kV/mm
- Operating temperature - 50 °C up to + 180 °C
shortly + 250 °C up to + 300 °C (soldering iron contact)
- Short circuit resistance SiR + 350 °C

Approvals and fire tests

(only 1,8/3 kV design)

- UL-Style 30119
- DIN EN 60332-1-2 /VDE 0482-332-1-2
- DIN EN 60332-3-24/VDE 0482-332-3-24
- DIN EN 61034-2/VDE 0482-1034-2
- DIN EN 50305 /VDE 0260-305 section 9.2

Approvals

(only 3,6/6 kV design)

- UL-Style 30120

Delivery

- Optionally in rings, on spools or wooden drums

		Technical data					
		Part-No.	Cross-section mm ²	Current load	Dimensions mm		
					Diameter and No. of wires	Outer-Ø ca.	Insulation thickness ca.
1,8/3 kV, double insulated		15170	2,5	41 A	651 x 0,07	6,2	1,1 + 1,0
		15172	4,0	55 A	1036 x 0,07	7,0	1,2 + 1,0
		15174	6,0	70 A	1568 x 0,07	8,1	1,2 + 1,2
		15176	10,0	98 A	2562 x 0,07	9,4	1,3 + 1,2
		15178	16,0	132 A	4116 x 0,07	10,7	1,3 + 1,2
		15180	25,0	176 A	3234 x 0,10	12,8	1,6 + 1,2
		15182	35,0	218 A	4508 x 0,10	14,7	1,6 + 1,5
		15184	50,0	276 A	6468 x 0,10	16,7	1,6 + 1,5
		15186	70,0	347 A	8967 x 0,10	19,3	1,6 + 1,8
		15188	95,0	416 A	12201 x 0,10	21,9	1,9 + 1,8
		15190	120,0	488 A	15432 x 0,10	24,4	2,0 + 2,1
		15192	150,0	566 A	19404 x 0,10	26,6	2,1 + 2,1
		15194	185,0	644 A	23580 x 0,10	30,6	2,4 + 2,4
		15196	240,0	775 A	30600 x 0,10	33,1	2,4 + 2,4
	15198	300,0	898 A	38200 x 0,10	37,5	2,4 + 2,4	
3,6/6 kV, double insulated		15138	2,5	43 A	651 x 0,07	8,4	2,0 + 1,2
		15140	4,0	56 A	1036 x 0,07	9,0	2,0 + 1,2
		15142	6,0	71 A	1568 x 0,07	9,7	2,0 + 1,2
		15144	10,0	99 A	2562 x 0,07	11,2	2,2 + 1,2
		15146	16,0	133 A	4116 x 0,07	12,5	2,2 + 1,2
		15148	25,0	174 A	3234 x 0,10	15,2	2,5 + 1,5
		15150	35,0	215 A	4508 x 0,10	16,5	2,5 + 1,5
		15152	50,0	270 A	6468 x 0,10	19,1	2,5 + 1,8
		15154	70,0	338 A	8967 x 0,10	21,1	2,5 + 1,8
		15156	95,0	403 A	12201 x 0,10	24,3	2,8 + 2,1
		15158	120,0	473 A	15432 x 0,10	26,0	2,8 + 2,1
		15160	150,0	546 A	19404 x 0,10	28,4	3,0 + 2,1
		15162	185,0	622 A	23580 x 0,10	32,2	3,2 + 2,4
		15164	240,0	750 A	30600 x 0,10	34,7	3,2 + 2,4
	15166	300,0	850 A	38200 x 0,10	38,3	3,2 + 2,4	

Remark: All information about current load are approximate values acc. to VDE 0298 part 4 table 15 for single laying of air cooled cables by an ambient temperature + 30 °C and allowed conductor heat of + 90 °C. By changing the ambient temperature or the kind of laying reducing factors are to be considered.

Highly flexible ready assembled connections manufactured out of silicone extruded cables

We manufacture highly flexible, ready assembled electrical connections from our silicone extruded cables for almost every application.

As standard designs, connections are available with seamless solderless pressed copper sleeves as well as cable lugs or plug connections. All single layer designs out of single insulated cables correspond to our UL-style 3858.



With crimped cable lugs



With additional insulation crimp

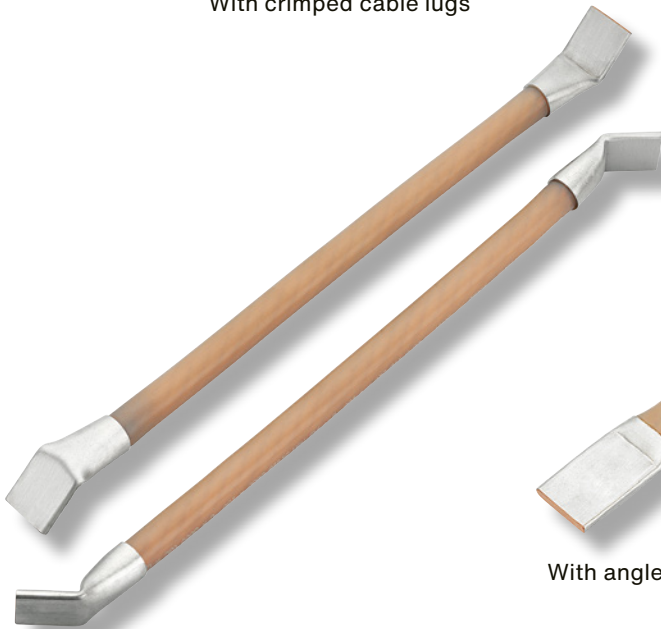

With angled connecting ends

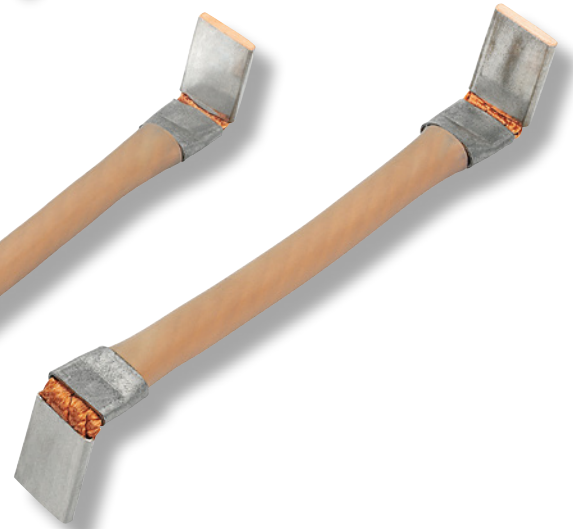

With crimped plugs and sockets

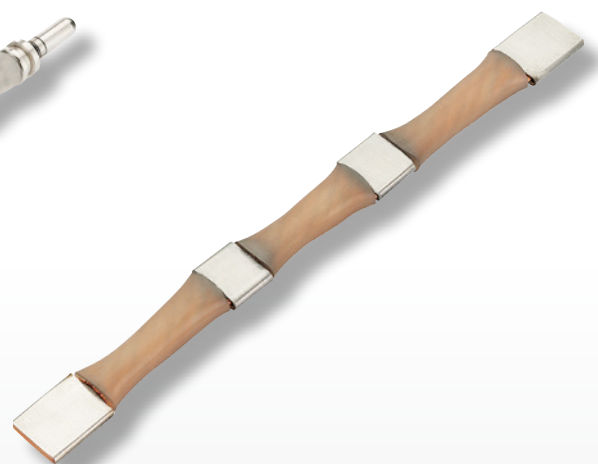

With several crimped contact areas

Highly flexible power connectors 50-300 mm² with solderless pressed contact ends

Highly flexible all-round movable ready assembled power connectors made out of single insulated silicone extruded cable 1,8/3 kV. Seamless contact sleeves are pressed on at the ends under high pressure without soldering, resulting in an extremely compact connection surface. Due to their very high flexibility and the possibility of movement on all sides, they are very suitable for use as power connections that carry out movements or have to connect devices and/or busbars in confined installation situation.

The technical data of the insulation material as well as the large temperature range from - 50 °C up to + 180 °C open up a multitude of possible applications for the user. Upon request, multi-layer designs are also available on one side combined in a single connection/contact area and on the other side with individual outlets of different lengths.

Standard designs



1-layer



2-layer

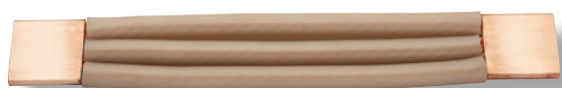

3-layer



4-layer

Special designs



Designs according to customer requirements on request e. g. with 90° offset designed connecting areas or several outlets.

Highly flexible power connectors 50-300 mm² with solderless pressed contact ends

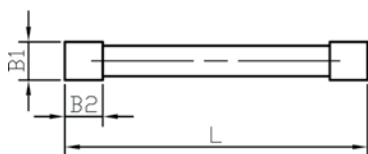
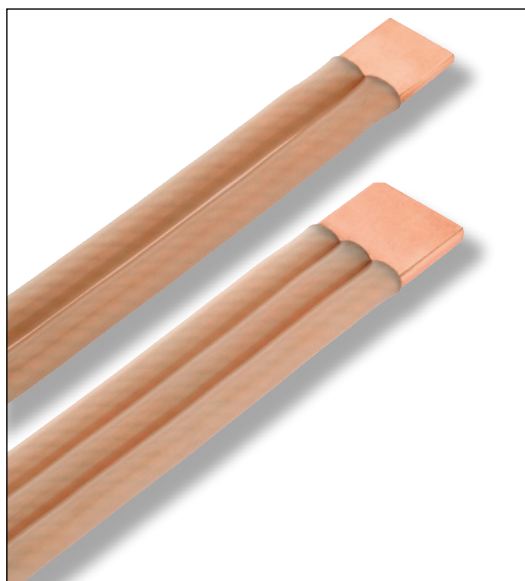

single layer design

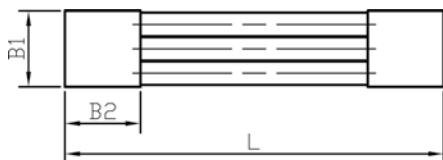

several layer design

On request also available with drilling or tinned contact areas

Technical data

Electrical conductor

- Round stranded copper cable out of Cu-ETP 1 wires acc. to DIN EN 13602
- Soft annealed, uncoated
- Single wire-Ø 0,10 mm

Connecting areas

- Copper tubing Cu-ETP, uncoated

Insulation

- Silicone rubber ca. 60 Shore A
- Natural-coloured
- Free of halogen, Chlorine content < 4 ppm
- Hardly inflammable, self-extinguishing
- Operating voltage 1,8/3 kV
- Testing voltage 10 kV AC (Sparktest)
- Dielectric strength 20 kV/mm
- Operating temperature - 50 °C up to + 180 °C shortly + 250 °C up to + 300 °C (soldering iron contact)

Approvals and fire tests of the cable

- UL-Style 3858
- DIN EN 60332-1-2/VDE 0482-332-1-2
- DIN EN 60332-3-24/VDE 0482-332-3-24
- DIN EN 61034-2/VDE 0482-1034-2
- DIN EN 50305/VDE 0260-305 Section 9.2

	Part-No.	Technical data					
		Cross-section mm ²	Diameter and No. of wires	Dimensions mm			L
				B ₁	B ₂	ca. S	
1-layer	14350	1 x 50	200 A	20	20	4,7	According to customer wishes
	14360	1 x 70	250 A	20	20	7,5	
	14370	1 x 95	300 A	25	25	6,7	
	14380	1 x 120	350 A	25	25	7,5	
	14390	1 x 150	400 A	30	30	7,7	
2-layer	14430	2 x 25	250 A	25	25	4,5	
	14440	2 x 35	300 A	30	30	5,0	
	14450	2 x 50	350 A	30	30	6,0	
	14460	2 x 70	480 A	40	40	6,7	
	14470	2 x 95	560 A	40	40	8,5	
	14480	2 x 120	650 A	40	40	9,1	
3-layer	14530	3 x 25	375 A	40	40	4,4	
	14540	3 x 35	450 A	40	40	6,0	
	14550	3 x 50	525 A	50	50	5,8	
	14560	3 x 70	720 A	50	50	7,8	
4-la.	14630	4 x 25	500 A	40	40	7,0	
	14640	4 x 35	600 A	50	50	6,5	

Remark: All information about current load are approximate values for single laying and ambient temperature + 30° in acc. with VDE 0298 part 4. In dependence of the allowed heat of the conductors it is likewise possible to work with higher current rates as recommend (in comparison to the tabular values acc. to page 5). If you need more information about planned applications don't hesitate to contact our company.

Highly flexible power connections 4-300 mm² with solderless pressed cable lugs

Highly flexible power connections made of silicone extruded single insulated cable 1,8/3 kV. Optional at the ends with solderless pressed tubular cable lugs or cable lugs according to DIN 46234. The space between lug and cable is covered by a silicon sleeve in all designs.

These ready assembled cables correspond like the cable itself to our UL-style 3858. UL-listed cable lugs with appropriate crimp technology can be found on the pages 25-30 of this leaflet. Technical data of the silicone extruded cable please look at page 5.

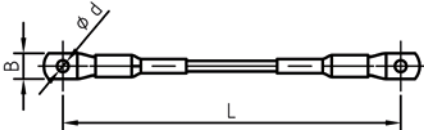

Design A with tubular cable lugs

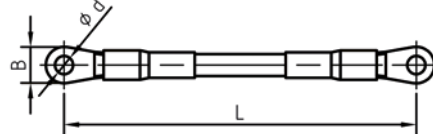

Design B with cable lugs DIN 46234



Part-No. Design A Design B	Technical data						
	Cross-section mm ²	Current load	Dimensions mm				L
			d	B Type A	B Type B	L	
16114 16210	4	30 - 55 A	5,3	10	10	According to customer wishes	
16115 16215	6	40 - 70 A	6,5	11	11		
16120 16220	10	50 - 98 A	6,5	12	11		
16125 16225	16	70 - 132 A	8,5	15	14		
16130 16230	25	95 - 176 A	8,5	16	16		
16135 16235	35	115 - 218 A	8,5	18	16		
16140 16240	50	145 - 276 A	10,5	22	18		
16145 16245	70	175 - 347 A	10,5	25	22		
16150 16250	95	215 - 416 A	13,0	29	24		
16155 16255	120	245 - 488 A	13,0	31	24		
16160 16260	150	285 - 566 A	13,0	35	30		
16165 16265	185	320 - 644 A	13,0	38	36		
16167 16267	240	380 - 775 A	13,0	44	38		
16169 -	300	435 - 898 A	17,0	49	-		

Remark: Designs with other cable lug drilling on request. All information about current load are approximate values for single laying and ambient temperature + 30 °C and conductor temperature ca. + 45 °C (min. value) resp. ca. + 90 °C (max value) in accordance with VDE 0298 part 4. Please refer to page 5 on this leaflet for detailed information of the used silicone cable and other current load values.

Individual acc. to customer requirements



Cable lugs crimped
90° offset

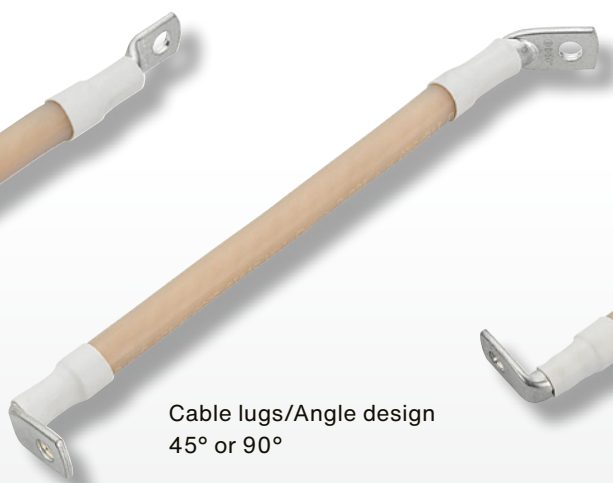

Cable lugs/Angle design
45° or 90°

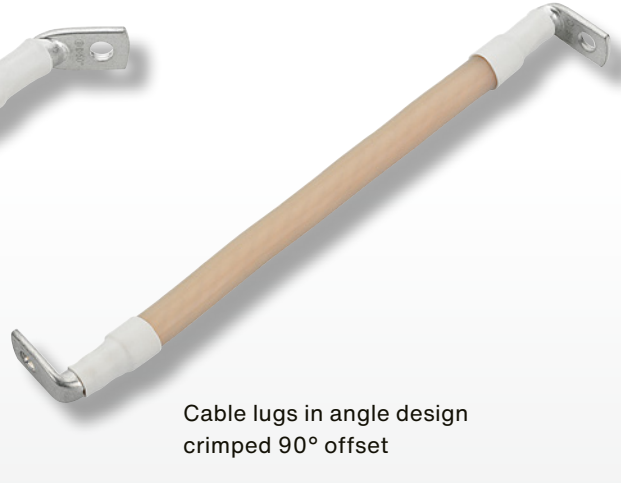

Cable lugs in angle design
crimped 90° offset

Highly flexible power connections 35-240 mm² with solderless pressed tubular cable lugs with narrow flange

Highly flexible power connections made of silicone extruded single insulated cable 1,8/3 kV. At the ends with solderless pressed tubular cable lugs with narrow flange. The space between cable lug and cable is covered by a silicon sleeve in all designs.

These ready assembled cables correspond like the cable itself to our UL-style 3858. UL-listed cable lugs with appropriate crimp technology can be found on the pages 25-30 of this leaflet. Technical data of the silicone extruded cable please look at page 5.

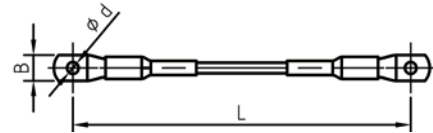

Part-No.	Technical data				
	Cross-section mm ²	Current load	Dimensions mm		
			d	B	L
16201	35	115 - 218 A	6,4	15	According to customer wishes
16202	50	145 - 276 A	10,5	19	
16203	70	175 - 347 A	10,5	19	
16204	95	215 - 416 A	13,0	22	
16205	120	245 - 488 A	13,0	22	
16206	150	285 - 566 A	13,0	26	
16207	185	320 - 644 A	13,0	30	
16208	240	380 - 775 A	13,0	30	

Remark: Designs with other cable lug drilling or 90° angled cable lugs on request. All information about current load are approximate values for single laying and ambient temperature + 30 °C and conductor temperature ca. + 45° C (min. value) resp. ca. + 90 °C (max value) in accordance with VDE 0298 part 4. Please refer to page 5 on this leaflet for detailed information of the used silicone cable and other current load values.

Comparison of tubular cable lugs with narrow flange and tubular cable lugs in standard design



The use of tubular cable lugs with a narrow flange in combination with our highly flexible cables allows connections to be made safely and permanently even under tight installation conditions.

So such connections offer very good solutions in the area of even smaller space in switch boards and switching devices.

Highly flexible pluggable power connections 10-120 mm²

Highly flexible pluggable power connections made of silicone extruded single insulated cable 1,8/3 kV (technical data of the cables acc. to page 5 of this leaflet). In standard design one side with solderless pressed tubular cable lug at the end and the other side optionally with solderless pressed plug or socket. Plugs and sockets with snap-in-locking system. They lock automatically when connected. Plugs are inserted only so far that the ring-snaps in.

To release, lightly turn and push in plug, than pull out. The space between crimp-connector and cable is covered by a silicone sleeve in all designs. On request, we also manufacture screw-in plug or socket parts for combination with our highly flexible cable sets. **All connections delivered ready assembled by us correspond like the silicone cable itself to our UL-style 3858.**

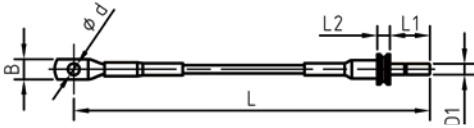

Design A with plug

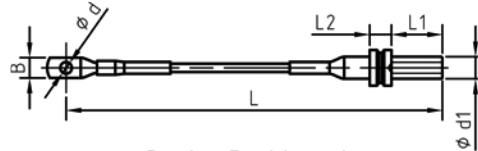

Design B with socket



Part-No. Design A Design B		Cross-section mm ²	Current load	Technical data					
				Dimensions mm					
				D/d ₁	L	L ₁	L ₂	d	B
16320	16325	10,0	80 A	6,0	According to customer wishes	22,0	7,0	6,5	11,0
16330	16335	16,0	100 A	6,0		22,0	7,0	8,5	15,0
16340	16345	25,0	130 A	10,0		42,5	12,0	8,5	16,0
16350	16355	35,0	150 A	10,0		42,5	12,0	8,5	17,0
16360	16365	50,0	190 A	14,0		43,0	17,0	10,5	22,0
16370	16375	70,0	240 A	14,0		43,0	17,0	10,5	25,0
16380	16385	95,0	280 A	14,0		43,0	17,0	13,0	29,0
16390	16395	120,0	300 A	14,0	43,0	17,0	13,0	31,0	

Remark: The specified current load is valid for an ambient temperature of 30 °C and a conductor temperature of ca. + 90 °C for single laying of an air cooled connector.

Plugs and sockets 80 A-300 A with snap-in lock and crimp connection



A detailed dimensional and technical description of the used plugs and sockets can be found in our general catalogue 1 "Professional installation- and electrical connection technology".

Highly flexible silicone insulated power connections ready assembled with additional insulation crimp

Manufactured out of single insulated silicone-extruded cables 1,8/3 kV. The special druseidt crimp-technology results in high quality moisture-proof electrical connection elements with very good vibration behavior. Therefore ideally suited for applications with vibrations, e. g. in the field of railways, wind power plants or screening machines.

Depending on the connection situation, the shape, dimensions of the contact areas and the position of the holes changes can be done in the technically possible frame. With pleasure we advise you on your applications. **All ready assembled articles delivered by us correspond like the cable itself, to our UL-style 3858.**

The special druseidt crimp-technology enables the production of power connections with large contact areas and an additional insulation crimp

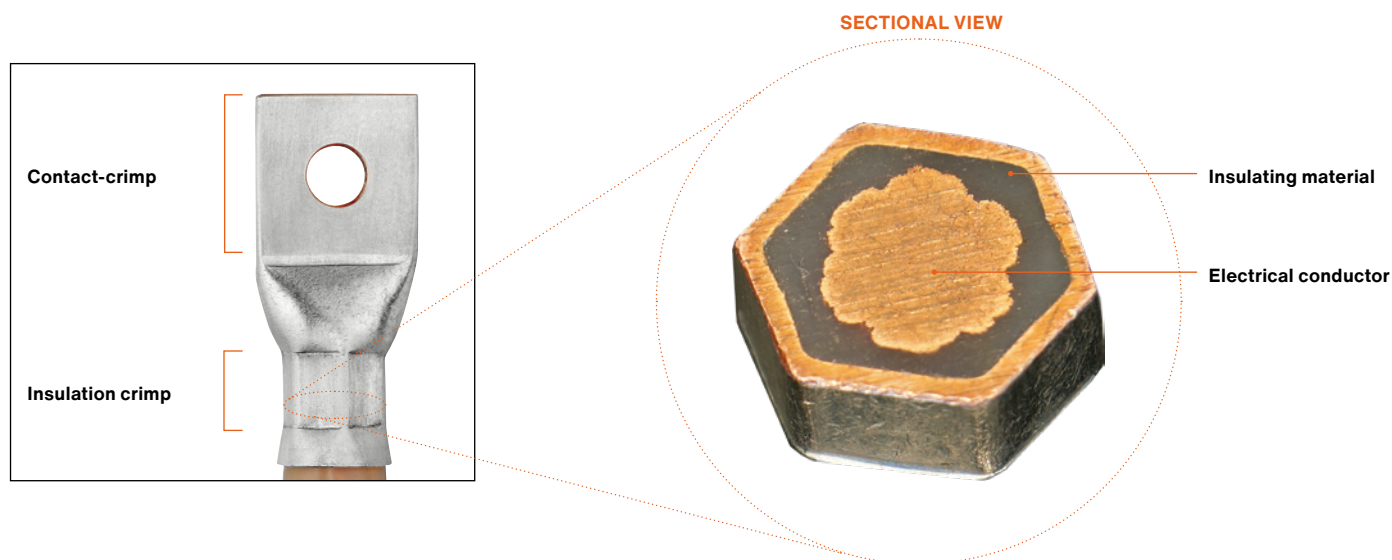

Advantages of the solderless crimped druseidt power connections

- The additional insulation-crimp shifts the buckling point to the insulated part of the cable when vibration occur and provides additional protection against moisture and dirt penetration
- This eliminates the need for an additional shrink tubing for sealing and prevents breaking of the electrical conductors at the junction between cable lug and conductor, as is possible when working with normal cable lug crimp-technology
- This considerably improves the service-life compared to cables with crimped cable lugs.
- The contact pressing takes place under very high pressure. This minimizes the electrical resistance, virtually eliminates breakage of the connection surfaces and guarantees a high aging ability of the connection
- Sufficiently dimensioned contact surfaces for optimized screwing/current transmission, e. g. by means of clamping discs according to DIN 6796
- Available in small and large series, adapted to the respective application

**Highly flexible power connections 10-300 mm²
out of single insulated silicone extruded cables 1,8/3 kV
with solderless crimped contact areas and additional insulation crimp**

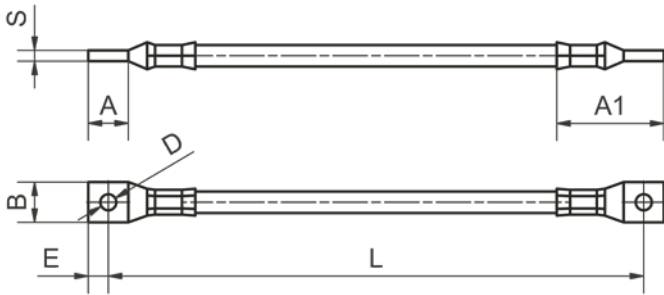

Technical Data

Electrical conductor

- Round stranded copper cable out of Cu-ETP 1 wires acc. to DIN EN 13602
- Soft annealed, uncoated
- Single wire-Ø 10/16 mm² 0,07 mm
- Single wire-Ø 25-300 mm² 0,10 mm

Connecting areas

- Copper tubing Cu-ETP, tinned

Insulation

- Silicone ca. 60 Shore A
- Natural-coloured
- Free of halogen, Chlorine content < 4 ppm
- Hardly inflammable, self-extinguishing
- Operating voltage 1,8/3 kV
- Testing voltage 10 kV AC (Sparktest)
- Dielectric strength 20 kV/mm
- Operating temperature - 50 °C up to + 180 °C

Approvals and fire tests

- UL-Style 3858
- DIN EN 60332-1-2 /VDE 0482-332-1-2
- DIN EN 60332-3-24/VDE 0482-332-3-24
- DIN EN 61034-2/VDE 0482-1034-2
- DIN EN 50305/VDE 0260-305 Section 9.2

Part-No.	Technical data								
	Cross-section mm ²	Current load	Dimensions mm						L
			A	A1	B	D	E	S	
16640	10	50 - 98 A	15	45	15	5,5	7,5	4,2	According to customer wishes
16641						6,5			
16642	16	70 - 132 A	15	45	15	5,5	7,5	4,2	
16643						6,5			
16644	25	96 - 176 A	20	50	20	6,5	10,0	4,2	
16645						9,0			
16647	35	115 - 218 A	25	60	25	9,0	12,5	4,8	
16648						11,0			
16650	50	145 - 276 A	25	60	25	9,0	12,5	4,6	
16651						11,0			
16653	70	175 - 347 A	25	65	25	9,0	12,5	5,9	
16654						11,0			
16656	95	215 - 416 A	30	70	30	11,0	15,0	5,7	
16657						14,0			
16659	120	245 - 488 A	30	70	30	11,0	15,0	8,0	
16660						14,0			
16662	150	285 - 566 A	35	80	35	14,0	17,5	8,4	
16665	185	320 - 644 A	35	80	35	14,0	17,5	9,1	
16668	240	380 - 775 A	40	95	40	14,0	20,0	10,6	
16669						17,0			
16671	300	435 - 898 A	40	95	40	14,0	20,0	12,7	
16672						17,0			

Remark: All information about current load are approximate values in consideration of the connector heat for single laying of air cooled cables and ambient temperature + 30 °C by conductor temperature app. + 45 °C (min. value) resp. + 90 °C (max. value) in acc. with VDE 0298 part 4. In dependence of the allowed heat of the conductors it is likewise possible to work with higher current rates as recommend (in comparison to the tabular values acc. to page 5). If you need more information about planned applications don't hesitate to contact our company.

Highly flexible power connections 70-300 mm²
 out of single insulated extruded cables 1,8/3 kV
 with solderless crimped contact areas and additional insulation crimp

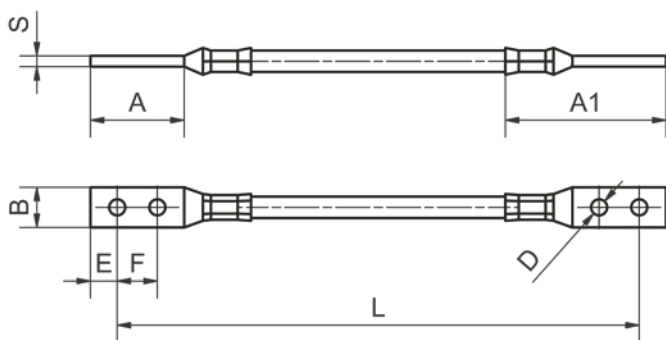
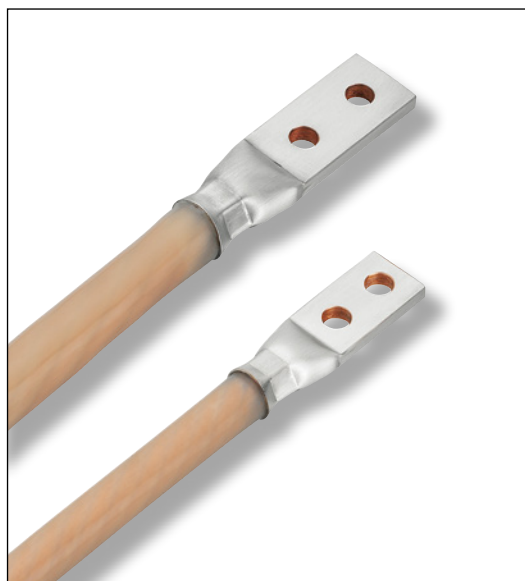

Technical Data

Electrical conductor

- Round stranded copper cable out of Cu-ETP 1 wires acc. to DIN EN 13602
- Soft annealed, uncoated
- Single wire-Ø 0,10 mm

Connecting areas

- Copper tubing Cu-ETP, tinned

Insulation

- Silicone ca. 60 Shore A
- Natural-coloured
- Free of halogen, Chlorine content < 4 ppm
- Hardly inflammable, self-extinguishing
- Operating voltage 1,8/3 kV
- Testing voltage 10 kV AC (Sparktest)
- Dielectric strength 20 kV/mm
- Operating temperature - 50 °C up to + 180 °C

Approvals and fire tests of the cable

- UL-Style 3858
- DIN EN 60332-1-2 /VDE 0482-332-1-2
- DIN EN 60332-3-24/VDE 0482-332-3-24
- DIN EN 61034-2/VDE 0482-1034-2
- DIN EN 50305/VDE 0260-305 Section 9.2

Part-No.	Technical data									
	Cross-section mm ²	Current load	Dimensions mm							
			A	A1	B	D	E	F	S	L
16600	70	175 - 347 A	50	90	25	9	12,5	25	5,9	According to customer wishes
16601			50	90		11	12,5	25		
16602			65	105	14	15,0	35			
16603	95	215 - 416 A	60	100	30	11	15,0	30	5,7	
16604			60	100		14	15,0	30		
16605			80	125	17	20,0	40			
16606	120	245 - 488 A	60	100	30	11	15,0	30	8,0	
16607			60	100		14	15,0	30		
16608			80	125	17	20,0	40			
16609	150	285 - 566 A	60	105	35	14	15,0	30	8,4	
16610			80	130		17	25,0	40		
16612			185	320 - 644 A	60	105	35	14	15,0	30
16613	80	120			17	20,0		40		
16615	240	380 - 775 A	80	135	40	14	20,0	40	10,6	
16616						17	20,0	40		
16618	300	435 - 898 A	80	135	40	14	20,0	40	12,7	
16619						17	20,0	40		

Remark: All information about current load are approximate values in consideration of the connector heat for single laying of air cooled cables and ambient temperature + 30 °C by conductor temperature app. + 45 °C (min. value) resp. + 90 °C (max. value) in acc. with VDE 0298 part 4. In dependence of the allowed heat of the conductors it is likewise possible to work with higher current rates as recommend (in comparison to the tabular values acc. to page 5). If you need more information about planned applications don't hesitate to contact our company.

Highly flexible power connections 10-300 mm²

out of single insulated silicone extruded cables 1,8/3 kV

with solderless crimped contact areas and additional insulation crimp

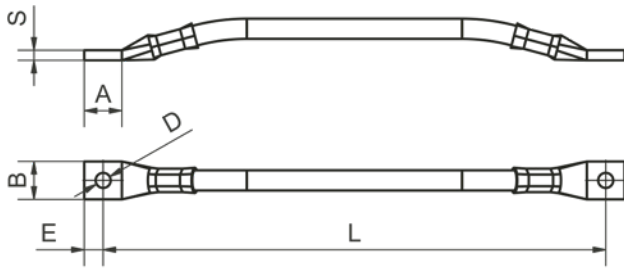
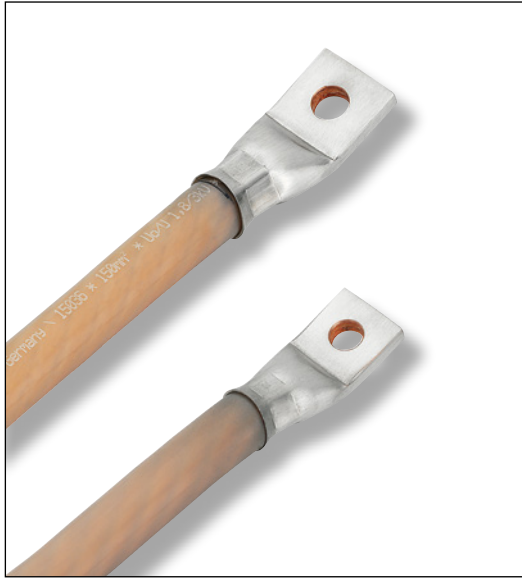

Technical Data

Electrical conductor

- Round stranded copper cable out of Cu-ETP 1 wires acc. to DIN EN 13602
- Soft annealed, uncoated
- Single wire-Ø 10/16 mm² 0,07 mm
- Single wire-Ø 25-300 mm² 0,10 mm

Connecting areas

- Copper tubing Cu-ETP, tinned

Insulation

- Silicone ca. 60 Shore A
- Natural-coloured
- Free of halogen, Chlorine content < 4 ppm
- Hardly inflammable, self-extinguishing
- Operating voltage 1,8/3 kV
- Testing voltage 10 kV AC (Sparktest)
- Dielectric strength 20 kV/mm
- Operating temperature - 50 °C up to + 180 °C

Approvals and fire tests of the cable

- UL-Style 3858
- DIN EN 60332-1-2 /VDE 0482-332-1-2
- DIN EN 60332-3-24/VDE 0482-332-3-24
- DIN EN 61034-2/VDE 0482-1034-2
- DIN EN 50305/VDE 0260-305 Section 9.2

Part-No.	Technical data							
	Cross-section mm ²	Current load	Dimensions mm					L
			A	B	D	E	S	
16740	10	50 - 98 A	15	15	5,5	7,5	4,2	According to customer wishes
16741					6,5			
16742	16	70 - 132 A	15	15	5,5	7,5	4,2	
16743					6,5			
16744	25	96 - 176 A	20	20	6,5	10,0	4,2	
16745					9,0			
16747	35	115 - 218 A	25	25	9,0	12,5	4,8	
16748					11,0			
16750	50	145 - 276 A	25	25	9,0	12,5	4,6	
16751					11,0			
16753	70	175 - 347 A	25	25	9,0	12,5	5,9	
16754					11,0			
16756	95	215 - 416 A	30	30	11,0	15,0	5,7	
16757					14,0			
16759	120	245 - 488 A	30	30	11,0	15,0	8,0	
16760					14,0			
16762	150	285 - 566 A	35	35	14,0	17,5	8,4	
16765	185	320 - 644 A	35	35	14,0	17,5	9,1	
16768	240	380 - 775 A	40	40	14,0	20,0	10,6	
16769					17,0			
16771	300	435 - 898 A	40	40	14,0	20,0	12,7	
16772					17,0			

Remark: All information about current load are approximate values in consideration of the connector heat for single laying of air cooled cables and ambient temperature + 30 °C by conductor temperature app. + 45 °C (min. value) resp. + 90 °C (max. value) in acc. with VDE 0298 part 4. In dependence of the allowed heat of the conductors it is likewise possible to work with higher current rates as recommend (in comparison to the tabular values acc. to page 5). If you need more information about planned applications don't hesitate to contact our company.

Highly flexible power connections 70-300 mm²
 out of single insulated silicone extruded cables 1,8/3 kV
 with solderless crimped contact areas and additional insulation crimp

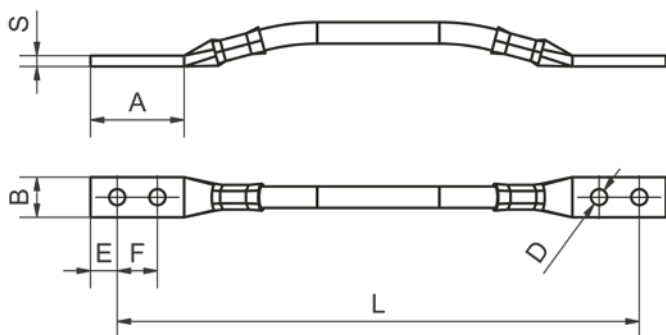
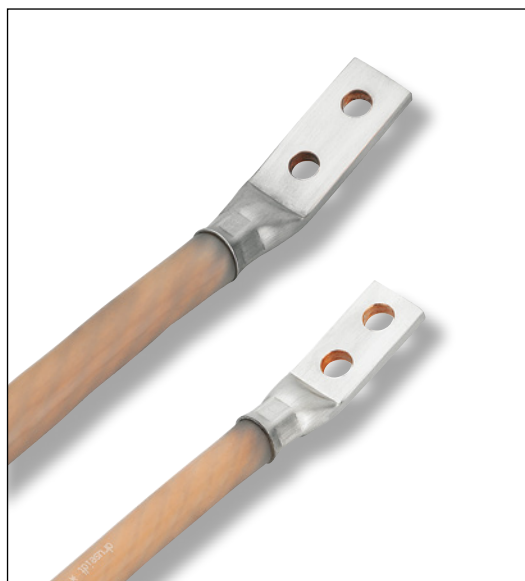

Technical Data

Electrical conductor

- Round stranded copper cable out of Cu-ETP 1 wires acc. to DIN EN 13602
- Soft annealed, uncoated
- Single wire-Ø 0,10 mm

Connecting areas

- Copper tubing Cu-ETP, tinned

Insulation

- Silicone ca. 60 Shore A
- Natural-coloured
- Free of halogen, Chlorine content < 4 ppm
- Hardly inflammable, self-extinguishing
- Operating voltage 1,8/3 kV
- Testing voltage 10 kV AC (Sparktest)
- Dielectric strength 20 kV/mm
- Operating temperature - 50 °C up to + 180 °C

Approvals and fire tests of the cable

- UL-Style 3858
- DIN EN 60332-1-2 /VDE 0482-332-1-2
- DIN EN 60332-3-24/VDE 0482-332-3-24
- DIN EN 61034-2/VDE 0482-1034-2
- DIN EN 50305/VDE 0260-305 Section 9.2

Part-No.	Technical data								
	Cross-section mm ²	Current load	Dimensions mm						L
			A	B	D	E	F	S	
16700	70	175 - 347 A	50	25	9	12,5	25	5,9	According to customer wishes
16701			50		11	12,5	25		
16702			65		14	15,0	35		
16703	95	215 - 416 A	60	30	11	15,0	30	5,7	
16704			60		14	15,0	30		
16705			80		17	20,0	40		
16706	120	245 - 488 A	60	30	11	15,0	30	8,0	
16707			60		14	15,0	30		
16708			80		17	20,0	40		
16709	150	285 - 566 A	60	35	14	15,0	30	8,4	
16710			80		17	25,0	40		
16712	185	320 - 644 A	60	35	14	15,0	30	9,1	
16713			80		17	20,0	40		
16715	240	380 - 775 A	80	40	14	20,0	40	10,6	
16716					17	20,0	40		
16718	300	435 - 898 A	80	40	14	20,0	40	12,7	
16719					17	20,0	40		

Remark: All information about current load are approximate values in consideration of the connector heat for single laying of air cooled cables and ambient temperature + 30 °C by conductor temperature app. + 45 °C (min. value) resp. + 90 °C (max. value) in acc. with VDE 0298 part 4. In dependence of the allowed heat of the conductors it is likewise possible to work with higher current rates as recommend (in comparison to the tabular values acc. to page 5). If you need more information about planned applications don't hesitate to contact our company.

**Highly flexible ready assembled cables,
manufactured out of silicone extruded cables with several outlets**

We also manufacture highly flexible pre-assembled connections with several outlets from our silicone extruded cables. They can be supplied with identical or differently long outlets with cable lugs or pressed-on contact sleeves. Even angled contact areas or connections with crimped plugs or sockets are no problem.

Our intensive manufacturing capabilities allow us to supply extremely flexible electrical connections precisely matched to your application. If required, our design department will be happy to support your efforts to create optimal power transmission solutions.



**Highly flexible silicone extruded braids,
as yards goods and ready assembled with welded contact areas**

In addition to our silicone extruded cables, we also produce versions consisting out of silicone extruded braids. The silicone material used for this purpose is also extremely flexible and enables the production of moveable and universally applicable connections, especially in conjunction with our welded contact areas.



Silicone extruded braids delivered by the meter



Silicone extruded braids
delivered with welded contact areas

Flexible braids delivered with welded contact areas
and a later fitted silicone tubing

Highly flexible silicone-extruded braids 10-140 mm², free of halogen, black coloured

Technical data

Electrical conductor

- Copper braid out of Cu-ETP 1 wires acc. to DIN EN 13602
- Soft annealed, uncoated
- Single wire-Ø 0,16 mm (10 mm²)
Single wire-Ø 0,20 mm (16-140 mm²)

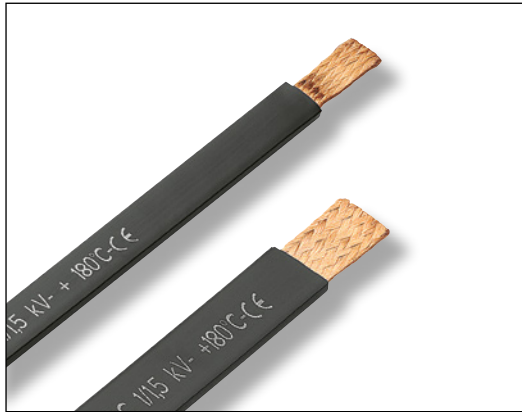

Insulation

- Silicone rubber circa 60 shore A
- Colour black
- Free of halogen, Chlorine content < 4 ppm
- Hardly inflammable and self extinguishing
- Operating voltage 1 kV AC/1,5 kV DC
- Testing voltage 9 kV (spark test)
- Dielectric strength 20 kV/mm
- Operating temperature - 50 °C up to + 180 °C

Delivery

- Optionally in rings, on spools or wooden drums

Part-No.	Technical data				
	Cross-section mm ²	Dimensions mm			
		Braid		With insulation	
		width	thickness	width	thickness
16300	10	12	1,3	16	5,3
16301	16	15	1,6	19	5,6
16302	25	20	1,6	24	5,6
16303	25	25	1,3	29	5,3
16304	35	20	2,3	24	6,3
16305	35	25	2,6	29	6,1
16306	50	25	2,4	29	6,6
16307	50	30	2,4	34	6,4
16308	70	25	3,5	31	7,5
16309	70	30	3,3	36	7,3
16310	70	35	2,8	41	6,8
16311	100	40	3,5	46	7,5
16312	120	40	4,1	46	8,1
16313	140	40	4,8	46	8,8

Remark: If desired, coloured designs (small minimum quantities required) are also deliverable e. g. green/yellow, red, orange or blue colour.

Highly flexible current- and grounding connectors 10-140 mm² out of silicone extruded braids with welded contact areas

This highly flexible connectors consist out of silicone extruded braids whose connection surfaces are welded solid. The result is an extremely flexible electrical connection, characterized by both cold- and heat resistant insulation (- 50 °C up to + 180° C). Ideally suited for electrical connections in applications where only a small amount of space is available or the connection needs to move.

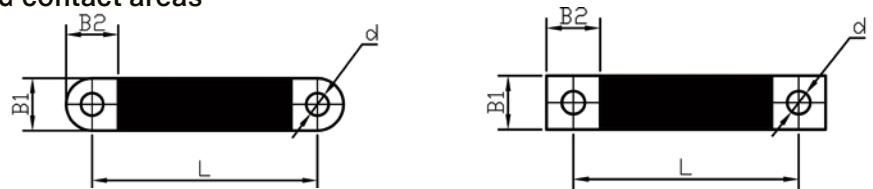

Design A

Design B

Best.-Nr. Design A	Best.-Nr. Design B	Technical data							
		Cross-section mm ²	Current load	Dimensions mm					L
				B ₁	B ₂	ca. S	d		
60500	60560	10	70 - 105 A	12	15	1,0	5,5		
60502	60562	16	100 - 150 A	15	15	1,2	6,5		
60504	60564	25	145 - 210 A	20	20	1,2	9,0		
60506	60566	25	145 - 210 A	25	25	1,0	11,0		
60508	60568	35	170 - 250 A	20	20	1,7	9,0		
60510	60570	35	170 - 250 A	25	25	1,5	11,0		
60512	60572	50	205 - 300 A	25	25	1,9	11,0		
60514	60574	50	205 - 300 A	30	30	1,9	11,0		
60516	60576	70	245 - 355 A	25	25	3,0	11,0		
60518	60578	70	245 - 355 A	30	30	2,6	11,0		
60520	60580	70	270 - 390 A	35	35	2,2	14,0		
60522	60582	100	325 - 470 A	40	40	2,8	14,0		
60524	60584	120	345 - 540 A	40	40	3,2	14,0		
60526	60586	140	375 - 580 A	40	40	3,8	14,0		

According to customer wishes

Remark: Designs with other hole-Ø on request. All information about current load are approximate values in consideration of the connector heat for single laying of air cooled connectors and ambient temperature + 35 °C. Minimum value = conductor temperature app. + 65 °C. Maximum value conductor temperature app. + 90 °C. The temperature of the conductor is in dependent of the installation, the application, the cooling, the ambient temperature and the heat removal option, so that, if necessary, reducing factors must be taken into account.

Flexible current-connectors 25-240 mm²
with welded contact areas in narrowly shaped design,
 suitable for connection of compact switches

Flexible current connectors with, in relation to the cross-section, narrowly shaped and solid welded contact areas. Therefore ideally suited for the connection of compact switches with narrow current outputs to busbar systems. The width of the connection surfaces are so designed that also supple bars can be replaced. Caused by the massively welded contact surfaces components with extremely low electrical resistance and excellent electrical aging behavior arise.

As standard insulation subsequently mounted silicone- or shrinking hoses are available. In particular the silicone insulated design offers a very good flexibility and a large temperature range from - 50 °C up to + 180 °C.



Technical data

Electrical conductor

- Copper braid out of Cu-ETP 1 wires acc. to DIN EN 13602
- Soft annealed, uncoated
- Single wire-Ø 0,15 mm

Insulation

Silicone tubing

- Silicone rubber circa 60 shore A
- Nature colour
- Free of halogen
- Hardly inflammable, self-extinguishing
- Dielectric strength > 18 kV/mm
- Thickness 1 mm
- Operating temperature - 50 °C up to + 180 °C

Heat shrinkable tubing

- Irradiated cross-linked polyolefin
- Black colour
- Self-extinguishing
- Dielectric strength 25 kV/mm
- Operating temperature - 55 °C up to + 125 °C

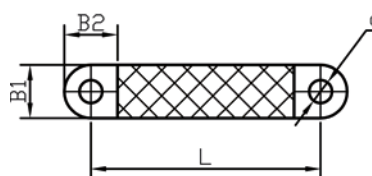

Part-No.			Technical data							
Without Insulation	Silicone insulated	Insulation shrinking tube	Cross-section mm ²	Current load	Suitable for switch-gear	Dimensions mm				
						B ₁	B ₂	ca. S	d	L
60600	60600-SI	60600-SH	25	145 - 210 A	125/163 A	12	15	1,9	5,5	According to customer wishes
60602	60602-SI	60602-SH	50	205 - 300 A	250 A	20	20	2,4	9,0	
60604	60604-SI	60604-SH	70	245 - 355 A	300 A	20	20	3,5	9,0	
60606	60606-SI	60606-SH	70	245 - 355 A	300 A	24	25	3,1	11,0	
60608	60608-SI	60608-SH	100	325 - 470 A	350 A	24	25	4,8	11,0	
60610	60610-SI	60610-SH	120	345 - 540 A	400 A	32	35	3,8	11,0	
60612	60612-SI	60612-SH	120	345 - 540 A	400 A	32	35	3,8	14,0	
60614	60614-SI	60614-SH	185	400 - 550 A	500 A	32	35	6,5	11,0	
60616	60616-SI	60616-SH	185	400 - 550 A	500 A	32	35	6,5	14,0	
60618	60618-SI	60618-SH	240	550 - 700 A	630 A	32	35	7,4	11,0	
60620	60620-SI	60620-SH	240	550 - 700 A	630 A	32	35	7,4	14,0	

Remark: Insulations in other colours or materials as well as other fixing holes on request. All information about current load are approximate values in consideration of the connector heat for single laying of air cooled connectors and ambient temperature + 35 °C. Minimum value = connector temperature app. + 65 °C. Maximum value conductor temperature app. + 90 °C. The temperature of the conductor is in dependent of the installation, the application, the cooling, the ambient temperature and the heat removal option, so that, if necessary, reducing factors must be taken into account.

Flexible power connectors 20-420 mm² in multilayer design with welded contact areas

These multi-layered flexible power strips with welded connection surfaces allow the transmission of currents up to 1000 A via compact and relatively narrow connection surfaces. They are therefore well suited for installation in confined spaces or to carry out movements with simultaneous flow of current.

The welding process used by us allows a compact and massive welding of both 2-layer and 3-layer power strips with a maximum total cross-section of 420 mm². As standard insulation subsequently mounted silicone- or shrinking hoses are available. In particular the silicone insulated design offers a very good flexibility and a large temperature range from - 50 °C up to + 180 °C.

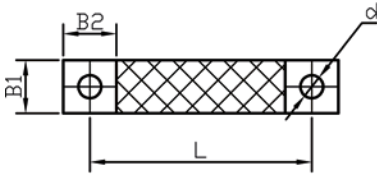

Technical data

Electrical conductor

- Copper braid out of Cu-ETP 1 wires acc. to DIN EN 13602
- Soft annealed, uncoated
- Single wire-Ø 0,16 mm (20/30 mm²)
- Single wire-Ø 0,20 mm (32-420 mm²)

Insulation

Silicone tubing

- Silicone rubber circa 60 shore A
- Nature colour
- Free of halogen
- Hardly inflammable, self-extinguishing
- Dielectric strength > 18 kV/mm
- Thickness 1 mm
- Operating temperature - 50 °C up to + 180 °C

Heat shrinkable tubing

- Irradiated cross-linked polyolefin
- Black colour
- Self-extinguishing
- Dielectric strength 25 kV/mm
- Operating temperature - 55 °C up to + 125 °C

Part-No.			Technical data						
Without Insulation	Silicone insulated	Insulation shrinking tube	Cross-section mm ²	Current load	Dimensions mm				
					B ₁	B ₂	ca. S	d	L
2-layer Design									
60640	60640-SI	60640-SH	20	110 - 160 A	12	15	1,9	5,5	According to customer wishes
60642	60642-SI	60642-SH	32	140 - 220 A	15	15	2,5	6,5	
60644	60644-SI	60644-SH	50	205 - 300 A	20	20	3,0	9,0	
60646	60646-SI	60646-SH	50	205 - 300 A	25	25	2,0	11,0	
60648	60648-SI	60648-SH	70	245 - 355 A	20	20	2,6	9,0	
60650	60650-SI	60650-SH	100	325 - 470 A	25	25	3,8	11,0	
60652	60652-SI	60652-SH	100	325 - 470 A	30	30	3,4	11,0	
60654	60654-SI	60654-SH	140	375 - 540 A	25	25	6,0	11,0	
60656	60656-SI	60656-SH	140	375 - 470 A	30	30	5,2	11,0	
60658	60658-SI	60658-SH	140	375 - 540 A	35	35	4,5	14,0	
60660	60660-SI	60660-SH	200	450 - 650 A	40	40	5,5	14,0	According to customer wishes
60662	60662-SI	60662-SH	240	550 - 700 A	40	40	6,4	14,0	
60664	60664-SI	60664-SH	280	600 - 800 A	40	40	7,7	14,0	
3-layer Design									
60670	60670-SI	60670-SH	30	125 - 205 A	12	15	2,3	5,5	According to customer wishes
60672	60672-SI	60672-SH	48	180 - 275 A	15	15	3,6	6,5	
60674	60674-SI	60674-SH	75	250 - 360 A	20	20	3,9	9,0	
60676	60676-SI	60676-SH	75	250 - 360 A	25	25	3,0	11,0	
60678	60678-SI	60678-SH	150	375 - 580 A	25	25	5,8	11,0	
60680	60680-SI	60680-SH	150	375 - 580 A	30	30	5,0	11,0	
60682	60682-SI	60682-SH	210	430 - 630 A	25	25	8,3	11,0	
60684	60684-SI	60684-SH	210	440 - 640 A	30	30	7,2	11,0	
60686	60686-SI	60686-SH	210	450 - 650 A	35	35	6,6	14,0	
60688	60688-SI	60688-SH	300	630 - 850 A	40	40	8,3	14,0	
60690	60690-SI	60690-SH	360	700 - 900 A	40	40	9,6	14,0	According to customer wishes
60692	60692-SI	60692-SH	420	800 - 1000 A	40	40	11,4	14,0	

Remark: Insulations in other colours or materials as well as with other fixing holes on request. All information about current load are approximate values in consideration of the connector heat for single laying of air cooled connectors and ambient temperature + 35 °C. Minimum value = connector temperature app. + 65 °C. Maximum value conductor temperature app. + 90 °C. The temperature of the conductor is in dependent of the installation, the application, the cooling, the ambient temperature and the heat removal option, so that, if necessary, reducing factors must be taken into account.

Mounting accessories dimensionally matched to our silicone extruded cables

For the in-house production of cable sets we supply all components as accessories from the appropriate cable lug with the matching crimp-technology via cable glands and plug connectors. Most of the parts are UL-listed components and with this the user is offered a complete, high quality connection system for in-house production.

On request, we can also produce customer-specific documentation on the applied crimp-technology in our laboratory (Micrographs with evaluation, pull-out tests, material- and electrical resistance tests etc.). In this way, the quality and its permanent maintenance can be reliably documented.

- Tubular cable lugs for fine stranded cables
- Silicone sleeves for cable lugs
- Tubular cable lugs with narrow flange for fine stranded cables
- Crimping tools and die sets for all fine stranded connectors
- Butt connectors for fine stranded cables
- Single- and two-piece cable glands

Design: WM-Crimping



Tubular cable lugs 10f-300f mm² for fine stranded cables

Material: Cu-HCP DIN EN 13600

Surface: tinned

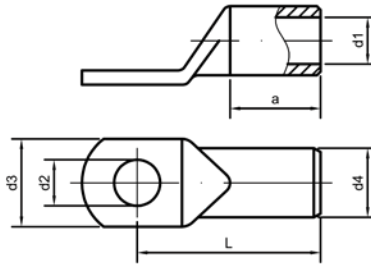

E 485326 up to 240f

Part-No.		Technical data									Weight kg/%o pcs.	Crimping tools/ page-no.
Without inspection hole	With inspection hole	Cross-section mm ²	Drilling M	d ₁	d ₂	Dimensions mm			L	a		
13650	13650/S	10f	5	5,0	5,3	12	8,0	23,0	12	7,00	Crimping tools for UL-compliant compression see pages 28-30. Further crimping tools can be found in our general catalogue 1 "Professional installation- and electrical connection technique for craft, industry and high current application".	
13651	13651/S		6		6,4	12		25,0		7,60		
13652	13652/S		8		8,4	15		28,0		8,90		
13653	13653/S		10		10,5	18		31,0		9,70		
13654	13654/S		12		13,0	20		32,0		10,00		
10700	10700/S	16f	5	6,0	5,3	14	9,0	25,5	13	9,40		
13655	13655/S		6		6,4	14		27,0		10,10		
13656	13656/S		8		8,4	15		29,5		11,20		
13657	13657/S		10		10,5	18		32,0		11,20		
13658	13658/S		12		13,0	20		33,0		11,80		
13659	13659/S	25f	6	7,7	6,4	16	10,7	32,0	16	14,70		
13660	13660/S		8		8,4	16		34,0		14,30		
13661	13661/S		10		10,5	18		35,0		15,30		
13662	13662/S		12		13,0	20		36,0		16,10		
10702	10702/S	35f	6	9,2	6,4	18	12,4	36,0	18	20,70		
13663	13663/S		8		8,4	18		36,0		20,70		
13664	13664/S		10		10,5	18		38,0		21,40		
13665	13665/S		12		13,0	23		40,0		22,20		
13666	13666/S		16		17,0	28		45,0		22,10		
10704	10704/S	50f	6	11,2	6,4	22	14,8	42,0	21	32,00		
13667	13667/S		8		8,4	22		42,0		32,20		
13668	13668/S		10		10,5	22		43,0		33,10		
13669	13669/S		12		13,0	23		44,0		33,60		
13670	13670/S		16		17,0	28		48,5		36,50		
13671	13671/S	70f	8	13,5	8,4	25	17,5	45,5	23	48,00		
13672	13672/S		10		10,5	25		47,0		48,40		
13673	13673/S		12		13,0	26		47,0		48,40		
13674	13674/S		16		17,0	28		50,0		50,50		
10706	10706/S		20		21,0	31		54,5		55,20		
10707	10707/S	95f	8	15,5	8,4	29	20,0	50,5	26	65,60		
13675	13675/S		10		10,5	29		53,0		71,50		
13676	13676/S		12		13,0	29		52,5		69,80		
13677	13677/S		16		17,0	29		55,0		71,90		
13678	13678/S		20		21,0	35		60,0		76,10		
13679	13679/S	120f	10	16,8	10,5	31	21,3	56,5	29	80,70		
13680	13680/S		12		13,0	31		56,0		80,70		
13681	13681/S		16		17,0	31		58,0		83,60		
13682	13682/S		20		21,0	35		63,0		87,50		
10708	10708/S	150f	10	19,0	10,5	35	24,0	59,0	30	104,00		
13683	13683/S		12		13,0	35		58,5		107,00		
13684	13684/S		16		17,0	35		63,0		111,10		
13685	13685/S		20		21,0	35		66,0		119,60		
10710	10710/S	185f	10	21,0	10,5	38	26,0	67,0	29	135,90		
10711	10711/S		12		13,0	38		67,0		121,50		
10712	10712/S		16		17,0	38		69,5		129,80		
10713	10713/S		20		21,0	38		71,0		134,50		
10714	10714/S	240f	12	24,0	13,0	35	30,0	44,0	30	212,60		
10715	10715/S		16		17,0	35		44,0		219,40		
10716	13716/S		20		21,0	35		44,0		222,00		
10718	-	300f	12	27,5	13,0	49	33,5	92,0	47	279,00		
10719	-		16		17,0	49		92,0		279,00		
10720	-		20		21,0	49		92,0		281,90		

**Tubular cable lugs 10f-300f mm²,
Angle type 90° for fine stranded cables**

Material: Cu-HCP DIN EN 13600

Surface: tinned

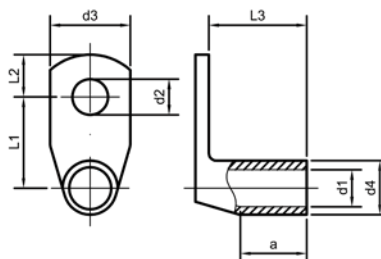

E 485326 up to 240f

Part-No.	Technical data										Weight kg/‰ pcs.	Crimping tools/ page-no.
	Cross-section mm ²	Drilling M	Dimensions mm									
			d ₁	d ₂	d ₃	d ₄	L ₁	L ₂	L ₃	a		
03410	10f	5	5,0	5,3	12,0	8,0	12,0	5,5	17,0	11	8,60	Crimping tools for UL-compliant compression see pages 28-30. Further crimping tools can be found in our general catalogue "Professional installation- and electrical connection technique for craft, industry and high current application".
03412		6		6,4	13,0		14,0	7,5			8,70	
03414		8		8,4	15,0		16,0	10,0			9,40	
03416		10		10,5	18,0		18,0	12,0			9,70	
03418		12		13,0	20,0		19,0	13,0			9,80	
03420	16f	5	6,0	5,3	15,0	9,0	12,5	5,5	17,0	12	9,40	
03422		6		6,4	15,0		14,5	7,5			10,50	
03424		8		8,4	15,0		16,5	10,0			11,80	
03426		10		10,5	18,0		18,5	12,0			12,50	
03428		12		13,0	20,0		19,5	13,0			14,30	
03430	25f	6	7,7	6,4	16,0	10,7	15,9	7,5	20,8	15	15,50	
03432		8		8,4	16,0		17,9	10,0			18,00	
03434		10		10,5	18,0		19,9	12,0			18,80	
03436		12		13,0	20,0		20,9	13,0			16,90	
03440	35f	6	9,2	6,4	18,0	12,4	16,7	7,5	21,5	17	19,70	
03442		8		8,4	18,0		18,7	10,0			22,00	
03444		10		10,5	18,5		20,7	12,0			23,40	
03446		12		13,0	23,0		21,7	13,0			22,30	
03448		16		17,0	28,0		24,7	16,0			22,50	
03450	50f	6	11,2	6,4	22,0	14,8	17,9	7,5	24,5	20	29,00	
03452		8		8,4	22,0		19,9	10,0			31,50	
03454		10		10,5	22,0		21,9	12,0			33,00	
03456		12		13,0	23,0		22,9	13,0			33,80	
03458		16		17,0	28,0		25,9	16,0			35,70	
03460	70f	8	13,5	8,4	25,0	17,5	21,3	10,0	28,0	22	45,30	
03462		10		10,5	25,0		23,3	12,0			48,20	
03464		12		13,0	25,0		24,3	13,0			50,63	
03466		16		17,0	28,0		27,3	16,0			51,00	
03468		20		21,0	31,0		31,3	19,0			54,00	
03470	95f	10	15,5	10,5	29,0	20,0	25,0	12,0	32,0	25	75,00	
03472		12		13,0	29,0		26,0	13,0			72,20	
03474		16		17,0	29,0		28,5	16,0			75,00	
03476		20		21,0	35,0		32,5	19,0			77,00	
03480	120f	10	16,8	10,5	31,0	21,3	25,7	12,0	34,0	28	78,60	
03482		12		13,0	31,0		26,7	13,0			80,20	
03484		16		17,0	31,0		29,7	16,0			83,30	
03486		20		21,0	35,0		33,7	19,0			86,10	
03490	150f	10	19,0	10,5	35,0	24,0	27,0	12,0	34,8	29	100,60	
03492		12		13,0	35,0		28,0	13,0			107,00	
03494		16		17,0	35,0		31,0	16,0			110,40	
03496		20		21,0	35,0		35,0	19,0			119,60	
03497	185f	12	21,0	13,0	38,0	26,0	29,0	13,0	43,0	34	126,90	
03498		16		17,0	38,0		32,0	16,0			134,60	
03499		20		21,0	38,0		36,0	19,0			140,20	
03500	240f	12	24,0	13,0	43,0	30,0	31,0	13,0	51,0	41	199,20	
03501		16		17,0	43,0		34,0	16,0			209,00	
03502		20		21,0	43,0		38,0	19,0			218,10	
03504	300f	12	27,5	13,0	49,0	33,5	34,8	14,5	58,0	46	313,00	
03505		16		17,0	49,0						313,00	
03506		20		21,0	49,0						313,00	

Butt connectors 10f-240f mm² for fine stranded cables

Material: Cu-HCP DIN EN 13600

Surface: tinned

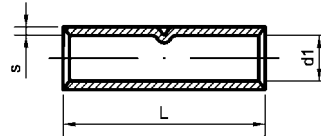

E 485326 up to 240f

Part-No.	Technical data					Crimping tools/ page-no.
	Cross-section mm ²	d ₁	Dimensions mm		Weight kg/‰/pcs.	
			L	s		
03800	10 f	5	30	1,5	8,30	See pages 28-30 or take a look in our general catalogue 1 "Professional installation- and electrical connection technique for craft, industry and high current application".
03801	16 f	6	35	1,5	11,00	
03802	25 f	7,7	40	1,5	15,00	
03803	35 f	9,2	45	1,6	21,80	
03804	50 f	11,2	50	1,8	32,40	
03805	70 f	13,5	60	2	51,00	
03806	95 f	15,5	65	2,25	74,90	
03807	120 f	16,8	65	2,25	84,40	
03808	150 f	19	70	2,5	105,60	
03809	185 f	21	85	2,5	140,10	
03810	240 f	24	100	3	227,30	

Tubular cable lugs 35f-240f mm² with narrow flange for fine stranded cables

Material: Cu-HCP DIN EN 13600

Surface: tinned

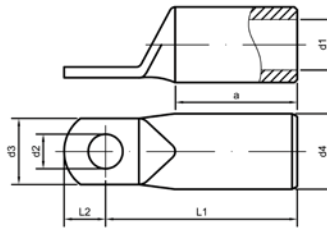

E 485326 up to 240f

Part-No.	Technical data										Crimping tools/ page-no.	
	Cross-section mm ²	Drilling M	Dimensions mm							Weight kg/‰ pcs.		
			d ₁	d ₂	d ₃	d ₄	L ₁	L ₂	a			
10850	35f	6	9,2	6,4	15	12,4	35,0	7,5	18	17,70	See pages 28-30 or take a look in our general catalogue 1 "Professional installation- and electrical connection technique for craft, industry and high current application".	
10852	50f	6	11,0	6,4	15	14,8	38,5	7,5	21	26,90		
10853		8	8,4	17	41,0	10,0	30,00					
10854		10	10,5	19	45,5	12,0	33,10					
10855		12	13,0	19	46,5	13,0	33,10					
10856	70f	6	13,4	6,4	18	17,5	47,5	7,5	23	45,10		
10857		8	8,4	18	48,0	10,0	47,00					
10858		10	10,5	19	50,0	12,0	47,40					
10859		12	13,0	22	51,0	13,0	46,30					
10861	95f	6	14,9	6,4	19	20,0	50,0	7,5	26	59,50		
10862		8	8,4	19	51,0	10,0	62,90					
10863		10	10,5	19	53,5	12,0	65,40					
10864		12	13,0	22	55,0	13,0	65,50					
10866	120f	6	16,3	6,4	19	21,3	53,0	7,5	29	68,40		
10867		8	8,4	19	55,0	10,0	71,10					
10868		10	10,5	19	57,0	12,0	73,40					
10869		12	13,0	22	58,0	13,0	76,30					
10871	150f	6	18,7	6,4	26	24,0	56,0	7,5	30	85,70		
10872		8	8,4	26	58,0	10,0	91,80					
10873		10	10,5	26	60,0	12,0	97,30					
10874		12	13,0	26	59,5	13,0	93,90					
10875		16	17,0	26	62,5	16,0	105,00					
10876	185f	10	21,0	10,5	30	26,0	65,0	12,0	35	117,20		
10877		12	13,0	30	65,0	13,0	112,70					
10878		16	17,0	30	68,0	16,0	117,60					
10880	240f	10	23,5	10,5	30	30,0	76,0	12,0	42	185,90		
10881		12	13,0	30	79,0	13,0	200,80					
10882		16	17,0	30	81,0	16,0	202,30					

Tubular cable lugs 35f - 240f with narrow flange for fine stranded cables

Angle type 90°

Material: Cu-HCP DIN EN 13600

Surface: tinned

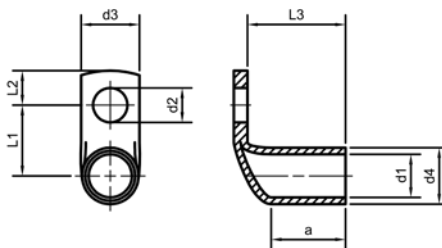

E 485326 up to 240f

Part-No.	Technical data											Crimping tools/ page-no.
	Cross-section mm ²	Drilling M	Dimensions mm									
			d ₁	d ₂	d ₃	d ₄	L ₁	L ₂	L ₃	a		
03960	35f	6	9,2	6,4	15	12,4	16,7	7,5	21,5	17	18,00	Crimping tools for UL-compliant compression see pages 28-30. Further crimping tools can be found in our general catalogue 1 "Professional installation- and electrical connection technique for craft, industry and high current application".
03961	50f	6	11,0	6,4	15	14,8	17,9	7,5	24,5	20	26,00	
03962		8		8,4	17		19,9	10,0			29,00	
03963		10		10,5	19		21,9	12,0			30,00	
03964	70f	6	13,4	6,4	18	17,5	20,0	7,5	31,0	22	43,00	
03965		8		8,4	18		22,0	10,0			45,00	
03966		10		10,5	19		24,0	12,0			48,00	
03967		12		13,0	22		27,0	13,0			48,00	
03968	95f	6	14,9	6,4	19	20,0	21,0	7,5	34,0	25	64,00	
03969		8		8,4	19		23,0	10,0			67,00	
03970		10		10,5	19		25,0	12,0			70,00	
03971		12		13,0	22		26,0	13,0			69,00	
03972	120f	6	16,3	6,4	19	21,3	21,7	7,5	37,0	28	73,00	
03973		8		8,4	19		23,7	10,0			77,00	
03974		10		10,5	19		25,7	12,0			79,00	
03975		12		13,0	22		26,7	13,0			78,00	
03976	150f	6	18,7	6,4	26	24,0	23,0	7,5	37,5	29	92,00	
03977		8		8,4	26		25,0	10,0			98,00	
03978		10		10,5	26		27,0	12,0			99,60	
03979		12		13,0	26		28,0	13,0			102,00	
03980		16		17,0	26		31,0	16,0			105,00	
03981	185f	10	21,0	10,5	30	26,0	28,0	12,0	43,0	34	119,00	
03982		12		13,0	30		29,0	13,0			119,00	
03983		16		17,0	30		32,0	16,0			123,00	
03984	240f	10	23,5	10,5	30	30,0	30,0	12,0	50,0	41	186,00	
03985		12		13,0	30		31,0	13,0			187,00	
03986		16		17,0	30		34,0	16,0			192,00	

Silicone sleeves

Natural coloured, free of halogen

Temperature resistant - 50 °C up to + 180 °C

Reach/RoHS compliant



Part-No.	Technical data			
	for cable Ø	Length	Inside- Ø	Thickness
10045	1,25 - 1,80	20	1,25	0,5
10046	1,75 - 2,50	20	1,75	0,5
10047	2,50 - 3,00	20	2,50	0,6
10048	3,00 - 4,00	25	3,00	0,6
10049	5,00 - 7,00	25	5,00	0,7
10050	7,50 - 9,00	30	7,50	0,8
10051	10,00 - 3,00	35	10,00	1,0
10052	12,00 - 6,00	50	12,00	1,2
10053	14,00 - 9,00	50	14,00	1,3
10054	17,00 - 5,00	50	17,00	1,3

Remark: Suitable for covering the transition between cable lug and silicone cable.
Suitable mounting tools and other accessories can be found in our general catalogue 1
"Professional installation- and electrical connection technique for craft, industry and high current application".

Battery operated hydraulic crimping and cutting tool 100 kN, druseidt-system with exchangeable tool heads



High quality tools „Made in Germany“ with WM-Crimping dies for UL-compliant-crimping of our tubular cable lugs and connectors for fine stranded cables.

Exchangeable tool heads

Crimping head



Cutting head



- Battery operated tools with exchangeable tool heads offer an economically and mobile crimping of cable lugs and connectors as well as cutting of copper- and aluminium cables.
- Deliverable tool heads
 - Part-No. 12753 collapsible crimping head for flat dies
 - Part-No. 12751 cutting head for copper and aluminium cables up to 54 mm Ø
- Two stage hydraulic system with quick feed and power stroke
- Collapsible, 360° rotating tool head
- Automatic pressure limit and monitoring by a pressure sensor
- Electronic control and inspection of the crimping cycle
- Quick motor stop and manual retraction
- Automatic motor stop and automatic retraction once crimp is completed (the automatic retraction function can be switched off in case of need)
- USB-interface for remote diagnosis
- USB-interface for connecting to all popular PC-systems
- Analysis-software with integration-, service- and monitoring function
- Optical failure- and stand-by indication system
- High performance Lithium-Ion battery
- 230 V mains adapter as accessory part

Battery operated hydraulic crimping and cutting tool 100 kN, druseidt-system with exchangeable tool heads

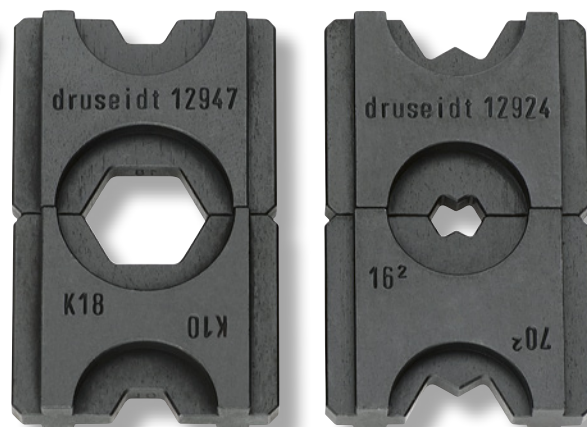

Further crimping designs and die-sets for a variety of cable lugs and connectors can be found in our general catalogue 1 "Professional installation- and electrical connection technique for craft, industry and high current application".

Part-No.	Cross-section range	Description/scope of supply
12748	10-240f resp. 300 mm ² for standard cable lugs	1 standard set consisting out of: 1 piece battery operated basic unit 100 kN without tool heads 1 piece Li-Ion battery 14,4 V, 2,6 Ah 1 piece battery charger 230 V 1 piece analysis software 1 piece USB connecting lead
12749		steel carrying case
12753		crimping head for flat dies
12751		cutting head for copper -and aluminium cables up to 54 mm Ø
Accessories		Technical data
13553	Replacement Li-Ion- battery 14,4 V, 2,6 Ah	<ul style="list-style-type: none"> • Crimping force: 100 kN • Max. stroke: 17 mm • Operating pressure: 700 bar • Crimping time: 3-6 Sec. (in dependance of the cross-section) • Li-Ion battery 14,4 V / 2,6 Ah • Time of loading: ca. 45 Min. • Battery charger: 230 V/50 Hz with 2 m connecting lead • Weight: with crimping head 5,3 kg with cutting head 6,1 kg
13554	Replacement battery charger 230 V	
13555	230 V mains adapter with 5 m connecting lead	
13538	Shoulder strap	

WM-Crimping 10f-240f mm²

for tubular cable lugs and connectors, druseidt design for fine stranded cables

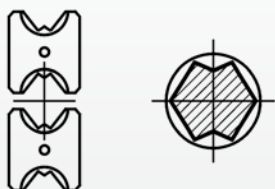

Part-No.	Cross-section mm ²	Crimping width mm	Remark
12492/UL	10f + 25f	7/12	The crimping dies listed here are used for UL-compliant crimping of the cable lugs and connectors for fine stranded cables listed in this catalogue.
12493/UL	16f + 35f	7/5	
12494	50f	5	
12495	70f	5	
12496	95f	5	
12497	120f	5	
12498	150f	5	
12499	185f	5	
12499/240f	240f	5	

Hydraulic compression heads and hydraulic-pumps

For crimping larger cross-sections, such as our 300 mm² cable lugs for fine stranded cables, crimping units with higher compression forces are required. Greater crimping widths can also be used here, thus considerably reducing the number of the necessary crimping processes. The following listed crimping head 05256 has a crimping force of 250 kN and can be used for cross-sections up to 630 mm².

Further information about other possible crimping designs and cross-sections as well as further versions of hydraulic pumps can be found in our general catalogue 1 "Professional installation- and electrical connection technique for craft, industry and high current application".

Hydraulic compression heads 250 kN suitable for connection to our 700 bar basic pumps

WM-crimping 10f-300f mm²
for tubular cable lugs and connectors
druseidt-design for fine stranded cables

Part-No.	Cross-section mm ²	Crimping width mm
14250	10f	7
14251	16f	10
14252	25f	12
14253	35f	14
14254	50f	14
14255	70f	14
14256	95f	14
14257	120f	14
14258	150f	14
14259	185f	14
14260	240f	14
14261	300f	14



Part-No.: 05256
Cross-section range: 10-630 mm²
Crimping force: 250 kN

Electro-hydraulic Pump operating pressure 700 bar



Part-No.	Operating pressure	Description/scope of supply
05254	700 bar	Electro-hydraulic pump with 1,8 m high pressure hose, hand switch and quick coupling without tool heads
05253		Double foot pedal for electro-hydraulic pump 05254

Technical data

- Operating pressure 700 bar
- Operating voltage: 230 V/50 Hz
- Nominal capacity: 0,4 kW
- Delivery rate: 0-20 bar 2 l/min
- Delivery rate: 20-700 bar 1,2 l/min
- Useable Oil volume: 0,8 liter, oil filling 1,2 liter
- Dimensions: 300 mm x 150 mm x 285 mm
- Weight: 8 kg

Remark: Handy two stage electro-hydraulic pump with pressure limiting valve and automatic changeover switching. Caused by the light weight and the small dimensions also well suited for mobile working.

Cable glands for droseidt silicone extruded cables

In order to ensure a safe damage-free feed-through of our highly flexible silicone insulated cables, we offer high quality cable glands as accessories. The brass and stainless steel versions with standard TPE-sealing inserts are also UL-compliant.

So we can offer a UL-compliant system consisting of single insulated silicone cables, cable lugs with crimp-technology and suitable cable glands. In addition to the standard designs, high-temperature, fire protection and splittable cable glands are also available.

Perfect accessories for droseidt cable glands

- Protection of the cable with optimum sealing
- Safe edge protection when entering the housings/switch cabinets
- Large-area sealing and high tightness IP 68 (dust and pressure water proof)
- High strain relief and high quality "Made in Germany"

Advantages of our cable glands

- Cable glands made of brass or stainless steel in standard design
- Cable glands made of brass or stainless steel in high-temperature design
- Cable glands made of brass or stainless steel in fire protection design
- Splittable cable glands, sealing inserts and nuts



“Our highly flexible silicone cables have been tested in conjunction with the offered cable glands.

The metal versions meet the requirements of the protection class IP 68 up to 15 bar pressure and, after ageing, exceed the requirements of the EN 62444 for strain relief design B.“

**Cable glands for druseidt silicone extruded cables,
Type A, B, C and D**



only Type A and Type B

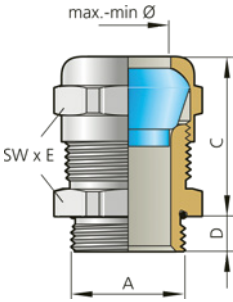

Part-No.				Technical data							
				Dimensions mm				Sealing range-Ø max./min.			
Type A	Type B	Type C	Type D	A	D	C	SW x E	Total	without inlet	with inlet	Packaging unit/pcs.
80000	80020	80080	80100	M16 x 1,5	6,0	25	20 x 22,2	11 - 4	11 - 7	7 - 4	50
80002	80022	80082	80102	M20 x 1,5	6,5	29	24 x 26,5	14 - 5	14 - 9	9 - 5	50
80004	80024	80084	80104	M25 x 1,5	7,5	30	30 x 33,0	20 - 11	20 - 16	16 - 11	50
80006	80026	80086	80106	M32 x 1,5	8,0	32	36 x 39,5	25 - 15	25 - 20	20 - 15	25
80008	80028	80088	80108	M40 x 1,5	8,0	35	45 x 48,0	32 - 20	32 - 26	26 - 20	10
80010	80030	80090	80110	M50 x 1,5	10,0	39	57 x 61,0	42 - 31	42 - 35	35 - 31	5

Type A: Material brass nickel plated, sealing insert TPE - 40 °C up to + 130 °C
Type B: Material stainless steel 1.4305, sealing insert TPE - 40 °C up to + 130 °C
Type C: Material brass nickel plated, sealing insert silicone - 55 °C up to + 180 °C
Type D: Material stainless steel 1.4305, sealing insert silicone - 55 °C up to + 180 °C
 An allocation table for the different cable glands to our silicone cables can be found on page 34.

**Fire protection designs
according EN 45545-2/3,
Type E, F, G and H**

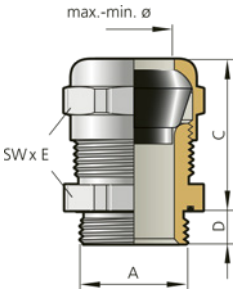

Part-No.				Technical data							
				Dimensions mm				Sealing range-Ø max./min.			
Type E	Type F	Type G	Type H	A	D	C	SW x E	Total	without inlet	with inlet	Packaging unit/pcs.
80040	80060	80120	80140	M16 x 1,5	6,0	25,0	20 x 22,2	11 - 4	11 - 7	7 - 4	50
80042	80062	80122	80142	M20 x 1,5	6,5	29,5	24 x 26,5	14 - 5	14 - 9	9 - 5	50
80044	80064	80124	80144	M25 x 1,5	7,5	29,5	30 x 33,0	20 - 11	20 - 16	16 - 11	50
80046	80066	80126	80146	M32 x 1,5	8,0	32,0	36 x 39,5	25 - 15	25 - 20	20 - 15	25
80048	80068	80128	80148	M40 x 1,5	8,0	35,0	45 x 48,0	32 - 20	32 - 26	26 - 20	10
80050	80070	80130	80150	M50 x 1,5	10,0	38,0	57 x 61,0	42 - 31	42 - 35	35 - 31	5

Type E: Material brass nickel plated, sealing insert TPE - 40 °C up to + 130 °C
Type F: Material stainless steel 1.4305, sealing insert TPE - 40 °C up to + 130 °C
Type G: Material brass nickel plated, sealing insert silicone - 55 °C up to + 180 °C
Type H: Material stainless steel 1.4305, sealing insert silicone - 55 °C up to + 180 °C
 An allocation table for the different cable glands to our silicone cables can be found on page 34.

**Lock nuts for cable glands
with metric thread acc. to EN 60423**



Part-No.	Technical data			Packaging unit/pcs.
	Dimensions mm			
	Thread	Mounting height	SW x E	
Material: Brass nickel plated				
80180	M16 x 1,5	2,8	19 x 21,0	50
80182	M20 x 1,5	3,0	24 x 26,7	50
80184	M25 x 1,5	3,5	30 x 33,5	50
80186	M32 x 1,5	4,0	36 x 39,0	25
80188	M40 x 1,5	5,0	46 x 50,0	10
80190	M50 x 1,5	5,0	55 x 60,0	5
Material: Stainless steel 1.4305				
80192	M16 x 1,5	3,0	19 x 21,0	50
80194	M20 x 1,5	3,0	24 x 26,6	50
80196	M25 x 1,5	4,0	27 x 29,5	50
80198	M32 x 1,5	5,0	36 x 39,0	25
80200	M40 x 1,5	5,0	46 x 50,0	10
80202	M50 x 1,5	5,0	55 x 60,0	5

**Splittable cable glands
with metric thread acc. to EN 60423**

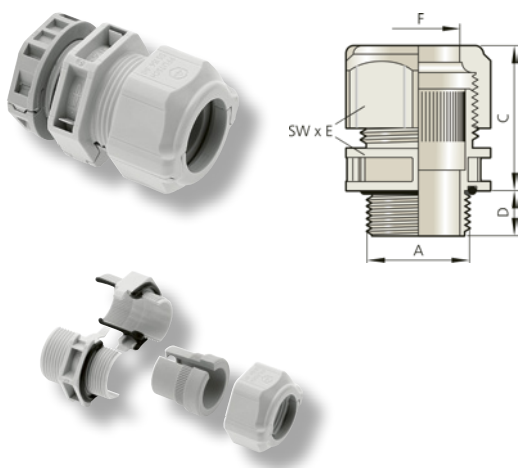

Part-No. gland body	Technical data					
	Connection thread	Dimensions mm				Packaging unit/pcs.
		D	F	C	SW x E	
80210	M20 x 1,5	10	15,0	29,7	30 x 33,5	10
80212	M25 x 1,5	11	20,5	38,5	35 x 38,5	10
80214	M32 x 1,5	14	27,0	39,6	46 x 51,3	10

Remark: Material PC grey. Temperature range - 20 °C up to + 80 °C.
Protection class IP 67. On request also available in black colour.

**Splitting inserts
for splittable PC cable glands**



Part-No.	Technical data				
	for cable gland/ thread	Sealing range mm	Dimensions mm		Packaging unit/pcs.
			for druseidt- silicone cables		
80220	80210/M20	6,5 - 5,0	15014-16/15170		25
80222		9,5 - 7,5	15020/15138/15172-74		25
80224	80212/M25	10,5 - 8,0	15022/15140-42/15176		25
80226		13,0 - 9,5	15024/15144/15178		25
80228	80214/M32	14,5 - 12,0	15026/15146/15180		25
80230		18,0 - 14,0	15028/15148-50/15182-84		25
80232		20,0 - 18,0	15030-32/15152/15186		25
80234		25,0 - 20,5	15034-36/15154-56/15188-90		25
80236		26,5 - 25,0	15038/15158/15192		25

Remark: Material TPE-V, temperature range - 40 °C up to + 135 °C.
Sealing inserts with other dimensions on request.

**Splittable locking nuts
with metric thread acc. to EN 60423**

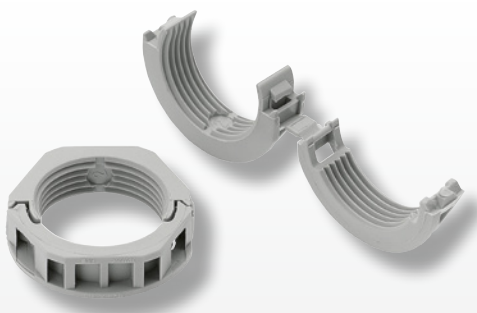

Part-No.	Technical data			
	Connection thread	Dimensions mm		
		Dimensions	SW x E	Packaging unit/pcs.
80250	M20 x 1,5	8	27 x 30	10
80252	M25 x 1,5	9	32 x 35	10
80254	M32 x 1,5	12	40 x 45	10

Remark: Material Polyamid grey. Temperature range - 40 °C up to + 100 °C. On request also available in black colour.

Allocation table for cable glands / silicone extruded druseidt cables

		Connection thread M16 x 1,5 mm Sealing range 11,0 - 4,0 mm	Connection thread M20 x 1,5mm Sealing range 14,0 - 5,0 mm	Connection thread M25 x 1,5 mm Sealing range 20,0 - 11,0 mm	Connection thread M32 x 1,5 mm Sealing range 25,0 - 15,0 mm	Connection thread M40 x 1,5 mm Sealing range 32,0 - 26,0 mm	Connection thread M50 x 1,5 mm Sealing range 42,0 - 31,0 mm
Cable glands standard Brass nickel plated Seal insert standard TPE	Part-No.	80000	80002	80004	80006	80008	80010
Cable glands standard Stainless steel 1.4305 Seal insert standard TPE	Part-No.	80020	80022	80024	80026	80028	80030
Fireprotection cable glands Brass nickel plated Seal insert standard T80s	Part-No.	80040	80042	80044	80046	80048	80050
Fireprotection cable glands Stainless steel 1.4305 Seal insert standard T80s	Part-No.	80060	80062	80064	80066	80068	80070
Cable glands for high temperature ranges Brass nickel plated Seal insert silicone	Part-No.	80080	80082	80084	80086	80088	80090
Cable glands for high temperature ranges Stainless steel 1.4305 Seal insert silicone	Part-No.	80100	80102	80104	80106	80108	80110
Fireprotection for cable glands in high temperature ranges Brass nickel plated	Part-No.	80120	80122	80124	80126	80128	80130
Fireprotection for cable glands in high temperature ranges Stainless steel 1.4305	Part-No.	80140	80142	80144	80146	80148	80150
for druseidt silicone cables							
single insulated 1,8/3kV		15014-22 4-16 mm ²	15016-24 6-25 mm ²	15026-30 35-70 mm ²	15030-36 70-150 mm ²	15038-40 185-240 mm ²	15042 300 mm ²
double insulated 1,8/3 kV		15170-78 2,5-16 mm ²	15170-80 2,5-25 mm ²	15180-86 25-70 mm ²	15184-90 50-120 mm ²	15192-94 150-185 mm ²	15196-98 240-300 mm ²
double insulated 3,6/6 kV		15138-42 2,5-6 mm ²	15138-46 2,5-16 mm ²	15146-52 16-50 mm ²	15150-56 35-95 mm ²	15158-60 120-150 mm ²	15162-66 185-300 mm ²
Temperature ranges of the sealing elements Standard TPE - 40 °C up to + 130 °C Fireprotection design T80s - 40 °C up to + 130 °C Standard silicone - 55 °C up to + 180 °C Silicone fireprotection design - 55 °C up to + 180 °C	Our flexible silicone cables have been tested in conjunction with the offered cable glands. They meet the requirements of the protection class IP 68 up to 15 bar pressure and, after ageing, exceed the requirements of the EN 62444 for strain relief design B.						

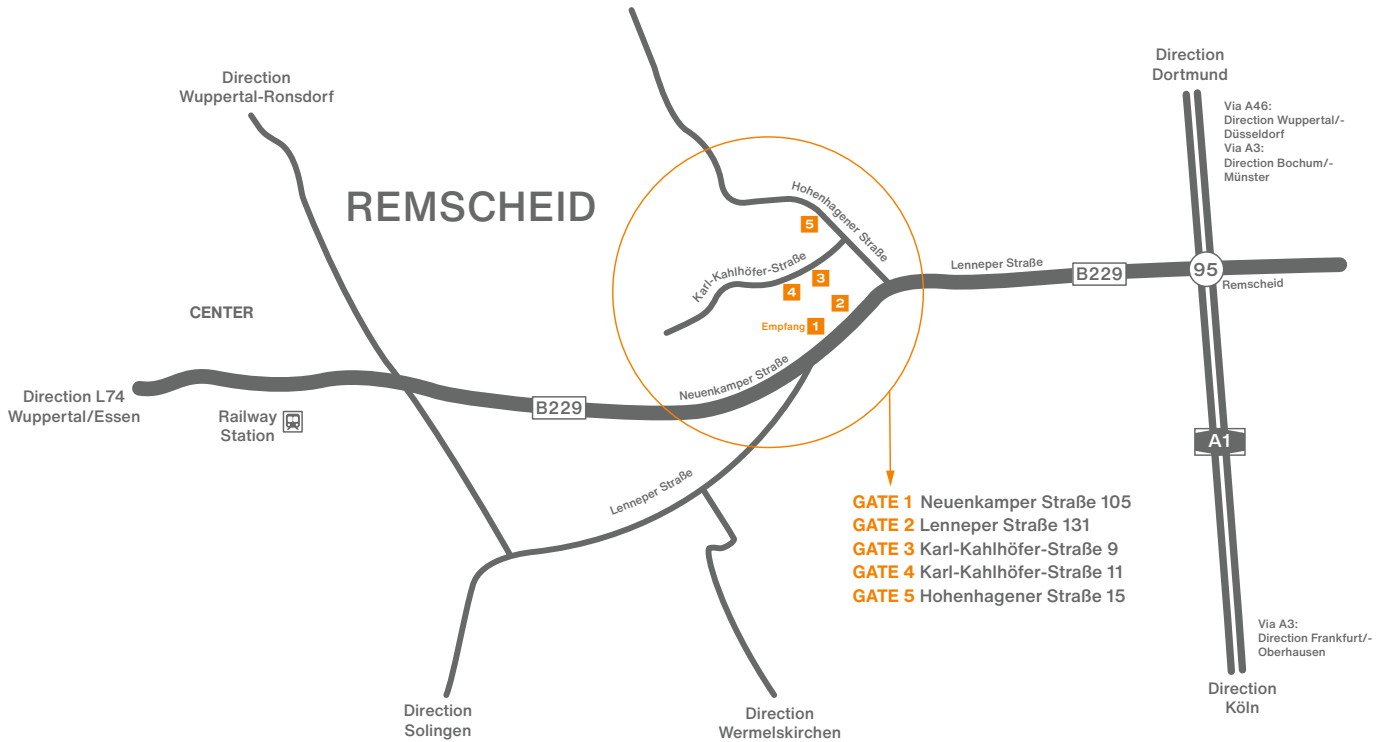

Paul Druseidt

Elektrotechnische Spezialfabrik GmbH & Co. KG

Neuenkamper Straße 105
42855 Remscheid - Germany

Phone: +49 (21 91) 93 52-0
 Fax: +49 (21 91) 93 52-150
 Web: www.druseidt.de
 E-Mail: info@druseidt.de

Monday - Thursday:
7:30 a.m. - 4:00 p.m
 Friday:
7:30 a.m. - 12:00 p.m



Visit our online shop and use the convenient product search as well as the convenient inquiry and ordering process..

Simply scan the QR code or enter it in your browser: shop.druseidt.de

Use our download area or order our special catalogues to the following subjects:

- „druseidt-Titan“ High current contact systems and cleaning devices (01/11)
- High current contact systems and cleaning devices type series up to 5000 A (02/11)
- Water cooled high current cables up to a cross-section range of 2000 mm² and high current pipe-systems (01/14)
- Water cooled high current cables preferably for electric arc- and ladle furnaces (02/14)
- Pneumatically actuated high current bolt contacts and switching units (01/18)
- Flexible power- and grounding connectors with welded contact areas (02/2018)
- Highly flexible silicone insulated cold- and heat resistant cables, ready assembled connectors (03/18)



DOWNLOAD